

MD CLAMP-ON PALLET FORKS

COFMD, COFMDSB

145200, 145210

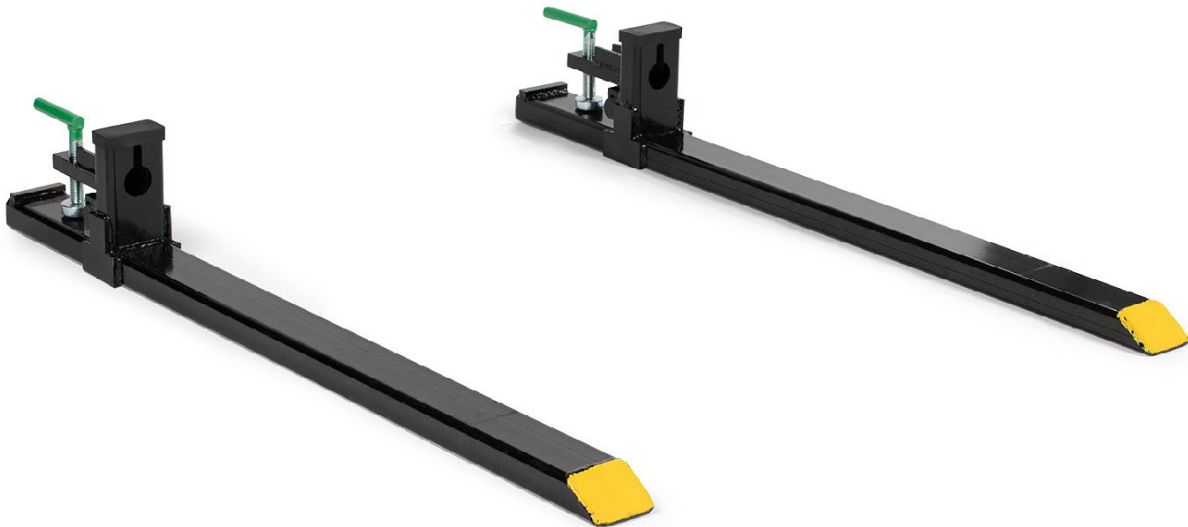

Operator's Manual



Read the Operator's Manual entirely. When you see this symbol, the subsequent instructions and warnings are serious follow without exception. Your life and the lives of others depend on it!

WARNING! READ MANUAL PRIOR TO INSTALLATION

Improper installation, operation, or maintenance of this equipment could result in serious injury or death. Operators should read and understand this manual as well as the prime mover's manual thoroughly before beginning installation, operation, or maintenance.

FOLLOW ALL SAFETY INSTRUCTIONS IN THIS MANUAL.

KNOW YOUR EQUIPMENT

Know your equipment's capabilities, dimensions, and operations before operating. Visually inspect your equipment before you start, and never operate equipment that is not in proper working order with all safety devices intact. Check all equipment to ensure it is properly installed and secured.

WARNING! SAFELY OPERATE EQUIPMENT

Do not operate equipment until you are completely trained by a qualified operator in how to use the controls, know its capabilities, dimensions, and all safety requirements. See your machine's manual for these instructions.

- Be sure the Clamp on Pallet Forks are full installed; clamp screws are in proper working order and clamped tightly to the bucket.
- In all instances, verify the load's weight prior to lifting. Never exceed the "maximum lift capacity" of the Clamp on Forks or the machine
- Lower the Clamp on Pallet Forks completely to the ground prior to dismounting from the machine. Understand and comply with the manufacturer's recommendations for dismounting and parking your machine.
- Always evenly load and secure pallets in such a way that they will not shift, tilt, or fall.

NOTICE!

- Misuse of the Pallet Forks can damage the forks and the bucket and can cause bodily injury or death. • Do not use Clamp on Pallet Forks for digging, pushing or pulling objects.
- It is recommended that all objects be secured and lifted on pallets. Unsecured loads can cause damage to the forks and/or bucket.
- Be sure that loads are evenly distributed and centered. Rated capacity is based on no more than 1/2 load per fork. Use the entire lifting area of the forks and avoid lifting loads more than half-way out from the bucket. Lifting loads that are unevenly distributed or using less than both fork's lifting area can cause damage to the forks and/or bucket.
- Keep load slightly tilted back to distribute weight towards the base of the forks.
- Do not lift loads that exceed the back height of the bucket.

- Backstops are highly recommended. They not only act as roll-back protection but can also provide a reference point for the fork location on the bucket. Use a 2x4 at least 30" in length.

OPERATING PALLET FORKS

- Verify load weight and confirm that it will not exceed lift capacity.
- Come to a complete stop prior to positioning the pallet forks at the correct height.
- Check for overhead obstructions.
- Be sure the load is balanced, secure and not too high.
- Center the forks under the pallet to distribute the weight of the load evenly.
- Move forward under the load utilizing as much of the forks lift area as possible.
- Slightly tilt the load back.
- Safe traveling height is about 3-5 inches above the floor and allows for maximum view.

TRAVELING WITH A LOAD

- Keep the forks low, just a few inches from the ground is best.
- If utilizing a backstop, slightly tilt the forks back to brace the load against the backstop.
- Be aware of everything around you. Avoid obstructions and always give pedestrians the right of way.
- Drive at a safe speed always. Take it easy around corners and avoid quick stops.
- Travel in reverse if the load obstructs your view.
- When possible, move straight up and down inclines, keeping the load on the "up-hill" side of the machine.
- Avoid adjusting the height of a load while in motion.
- Always be aware of changes in terrain. When working on inclines, declines, or on a hillside, do not raise the load too high.
- Always use a "spotter" with heavier loads, or when the operator's view is obstructed. The spotter must be positioned at a safe distance from the load and machine.

LOAD PLACEMENT

- Slowly move load into position. Make sure load is square and straight.
- Always come to a complete stop before placing a load.
- Be sure load is tilted forward to level.
- Place load and relieve all weight from forks.
- Scan area and be sure no pedestrians or obstructions are behind you.
- Once load is settled, slowly back out.
- Do not turn machine until both forks have cleared the pallet.
- Lower forks to a safe traveling height before moving again. Three to five inches is best.

MOUNTING THE FORKS

FORK MOUNTING

- Set the bucket on blocks or raise with your machine.
- Attach the forks to the bucket and secure the clamps.

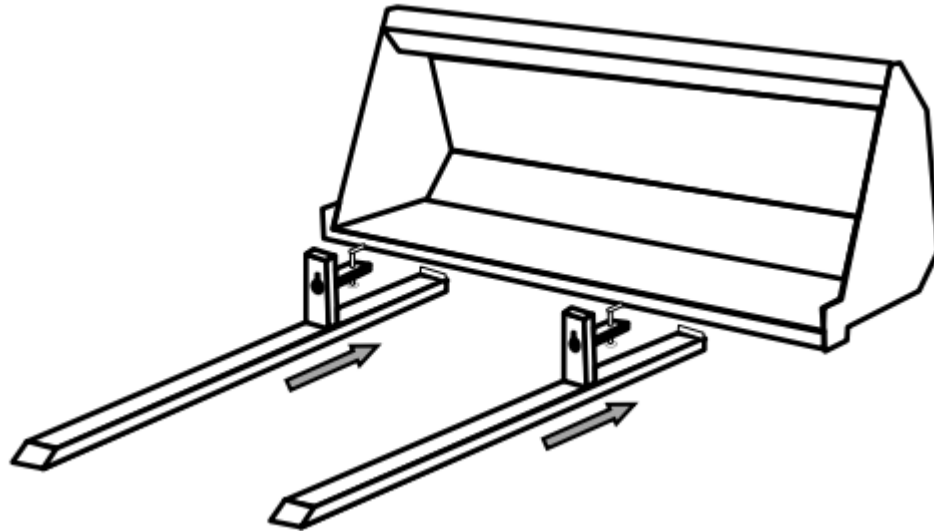

OPTIONAL STABILIZER BAR INSTALLATION (ADDITIONAL PURCHASE)

- Adjust the width of the stabilizer bar using the bolt located on the cross bar.
- Position the stabilizer bar on the forks and secure by tightening the bolts on the outer side of the forks.

NOTE: Stabilizer bars are not always necessary but are available as an option to provide maximum stability to your forks.

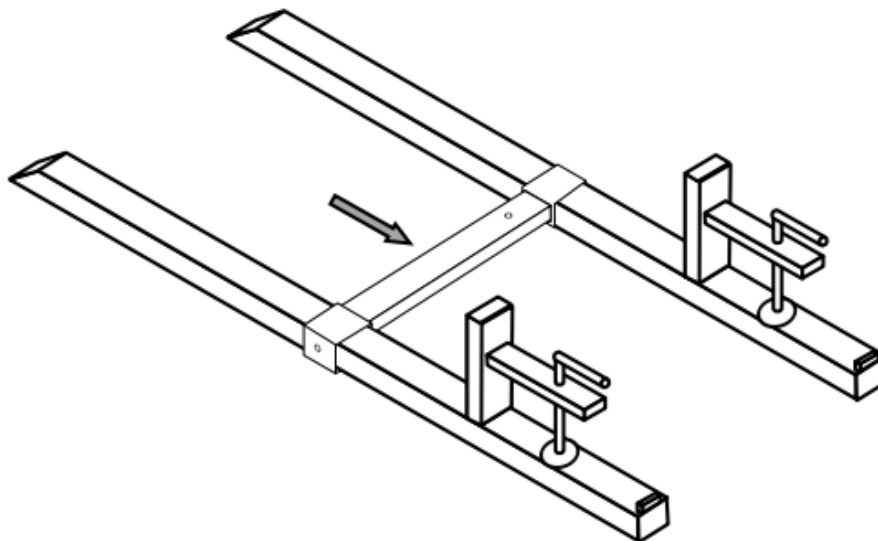

OPTIONAL CHAIN INSTALL (LOCAL STORE PURCHASE)

- Set the bucket on blocks or raise with your machine.
- Run a chain around the back side of your bucket and hook in the proper mounting holes located on the top and bottom of the fork and tighten with a ratchet binder.
- Repeat the above step with a separate chain when securing multiple forks.

NOTE: Chains are not always necessary. However, inserts on the forks provide the option to utilize additional hardware to deliver extra support when moving heavy loads.

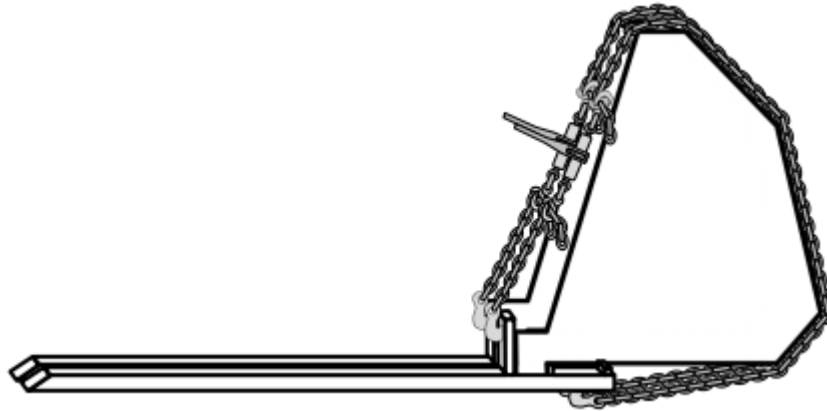

OPTIONAL BACKSTOP INSTALL (LOCAL STORE PURCHASE)

- Use a 2x4 that is at least 30 inches long for an upright backstop.
- The 2x4's used on the COFLW (1500lb) model will need to be cut to 2 6/8" width for the lower 7" length of the 2x4.
- The 2x4 backstops for the COFMD (4000lb) and COFHD (6000lb) model forks can be used without any width modifications.

NOTE: Backstops are not always necessary. However, 2x4s can be utilized to provide optimal protection and stability when moving an unbalanced load.

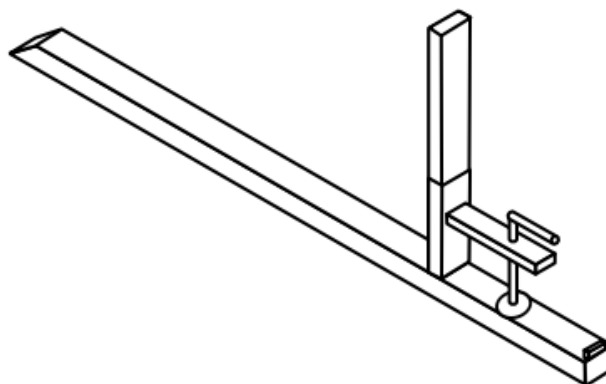

TROUBLESHOOTING

PROBLEM	POSSIBLE CAUSE	REMEDY
CAN'T LIFT PALLET	Load Exceeds Lifting Capacity	Reduce load on pallet Use alternate machine
	Single Fork Overload	Redistribute load weight evenly Secure with chains
	Bucket Bending	Tighten clamps Reduce load on pallet Use alternate bucket Shim under clamps with 1/2" steel plate.
REAR TIRE SLIPPING	Tractor is too small	Reduce load on pallet Use bigger machine Add weight to rear
	Not enough traction	Add weight to rear Check tire pressure Replace tires
BENT OR DAMAGED BUCKET	Pallet forks are loose	Tighten clamps Use shim plate
	Load is too heavy	Lessen the load Secure with chains
	Bucket is in poor condition	DO NOT use bucket!
	Single fork overload	Spread the forks further apart. Redistribute load weight evenly.

TROUBLESHOOTING

PROBLEM	POSSIBLE CAUSE	REMEDY
BENT OR DAMAGED FORKS	Load Exceeds Fork Capacity	Reduce load on pallet Secure with chains
	Load is picked up using less than half of the fork.	Move forks further under the pallet.
	Single fork overload	Distribute load weight evenly. Tighten clamps/secure with chains.
	Pallet frozen or partially buried.	Re-stack on new pallet.

ACKNOWLEDGEMENT OF RISK AND RELEASE OF LIABILITY

The use of any equipment, including this one, involves the potential risk of injury. Apart from any warranty claim that might be presented for a claimed defect in material or workmanship of the product, you accept and assume full responsibility for any and all injuries, damages (both economic and non-economic), and losses of any type, which may occur, and you fully and forever release and discharge Titan, its insurers, employees, officers, directors, associates, and agents from any and all claims, demands, damages, rights of action, or causes of action, present or future, whether the same be known or unknown, anticipated, or unanticipated, resulting from or arising out of the use of said equipment.

This equipment must be used with care by capable and competent individuals under supervision, if necessary.

WARNING



Do not overfill! Mower should be level when checking oil in gear box.



some activities might be able to cause electric shock



Sharp objects may be involved.
Use protective cover during maintenance.

TITAN LIMITED WARRANTY: TERMS, EXCLUSIONS AND LIMITATIONS OF REMEDIES

This product comes with a one (1) year limited warranty that can be found at www.palletforks.com/warranty.html. Please review the same for all details regarding the Titan Limited Warranty.

THE TITAN LIMITED WARRANTY FOUND AT WWW.PALLETFORKS.COM/WARRANTY.HTML IS EXCLUSIVE AND IS IN LIEU OF ALL OTHER WARRANTIES, EXPRESS OR IMPLIED, INCLUDING ANY IMPLIED WARRANTY OF MERCHANTABILITY AND/OR FITNESS FOR A PARTICULAR PURPOSE, EACH OF WHICH IS HEREBY DISCLAIMED.



NEED HELP? CONTACT US FIRST.

1-800-605-7595

info@palletworks.com
www.palletforks.com

© 2021 Titan Brands