

TITAN RAMPS

CHROME MOTORCYCLE WHEEL CHOCK
INSTRUCTION MANUAL

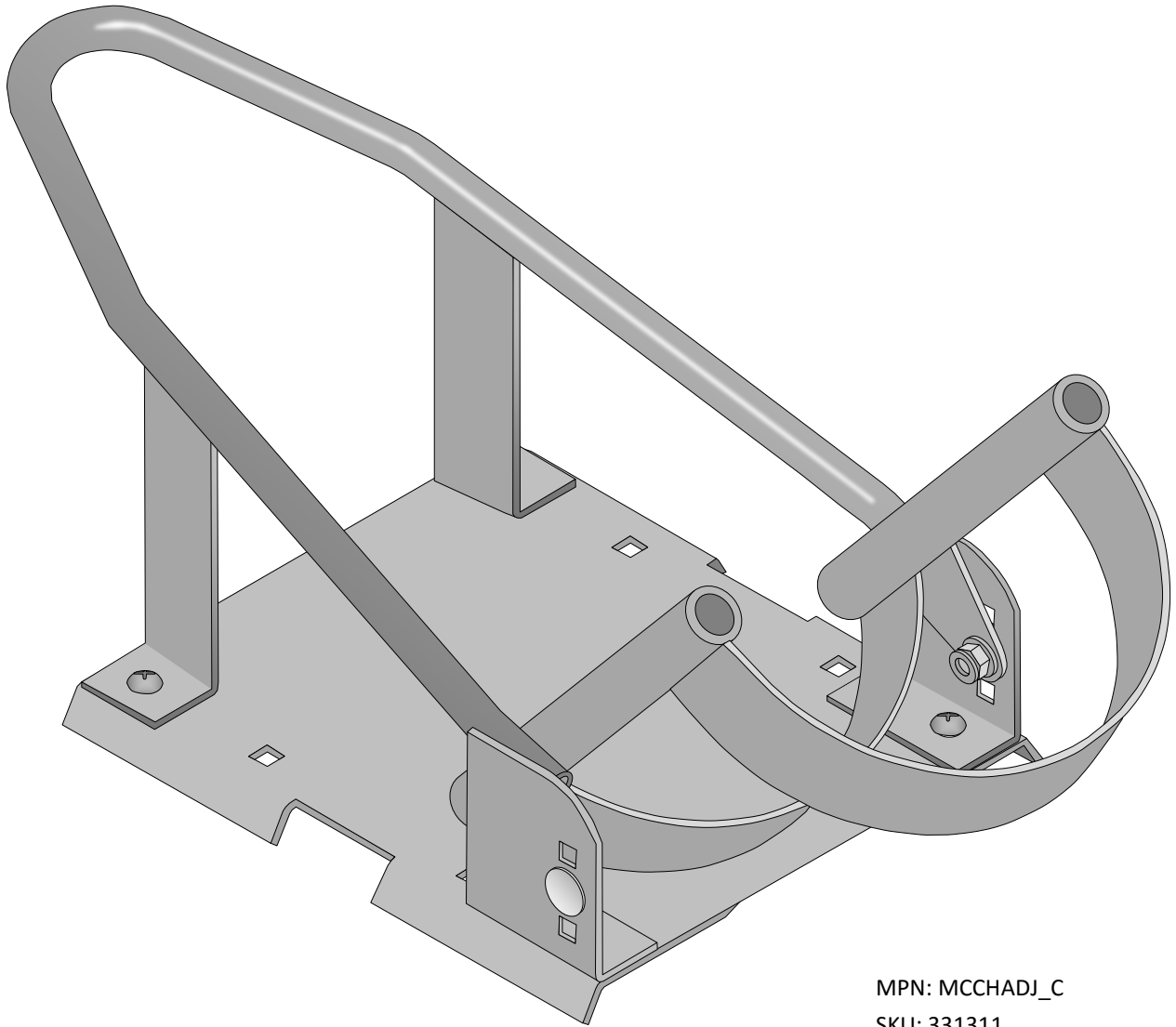

MPN: MCCHADJ_C
SKU: 331311



Titan Distributors Inc.
141 Eastley St. Ste. 113
Collierville, TN 38017

1 800-605-8241

info@titanramps.com

www.titanramps.com

USE THE CORRECT PRODUCT FOR YOUR MOTORCYCLE. MAKE SURE THE MOTORCYCLE'S WHEEL FITS INTO THE WHEEL CHOCK PRIOR TO FIRST USE.

WARNING:



The warnings, cautions, and instructions discussed in this instruction manual cannot cover all possible conditions or situations that could occur. It must be understood by the operator that common sense and caution are factors which cannot be built into this product, but must be supplied by the operator.

WARNING:



Do not sit on the motorcycle while it is being loaded into the Wheel Chock.

WARNING:



Verify that the installation surface has no hidden wires, brake lines, etc. before drilling.

Concrete Floor Mounting

- Choose a location that is flat, level and capable of bearing the combined weight of the Wheel Chock and the motorcycle. Make sure that the location is out of the way and there is sufficient room to remove the motorcycle after it has been mounted. The mounting surface should be suitable for heavy equipment.
- Use the mounting holes in the Base (1) of the Wheel Chock as a template. Arrange the Base (1) in the chosen location and, using a pencil, mark where the holes are to be drilled. You will need concrete anchors (not included) to secure the Base (1) to the concrete floor. Using the correct size concrete drill bit (not included), drill the mounting holes to secure the Base (1). Attach the concrete anchors to the floor. Secure the Base (1) to the floor utilizing the concrete anchors.

Truck Bed or Motorcycle Lift Mounting

- Place the Base (1) over the desired location in the truck bed or motorcycle lift. Use the Base (1) for a pattern and mark where you the holes need to be drilled in order to mount the Wheel Chock. Use a drill (not included) and a steel cutting bit (not included) to drill the holes in the truck bed or motorcycle lift.
- Attach the Base (1) to the truck bed utilizing the Mounting Bolts (8) and Nylon Sleeves (7). Secure with Flanged Hex Nuts (6). See Diagram and Parts List.

WARNING:

Do not drive motorcycle into the Wheel Chock.



- Select the correct mounting hole for the motorcycle being loaded into the Wheel Chock, and use the Pivot Bolts (5) to secure the Pivoting Bracket in place.
- To load a motorcycle, lower the Pivoting Bracket (3) to the horizontal position and simply pushing the motorcycle into the Wheel Chock.
- The Pivoting Bracket will close on the motorcycle tire, securing the bike in an upright position.
- For long-term storage, or if the Wheel Chock is mounted to a mobile platform, the motorcycle should be secured with belts or straps (not included).

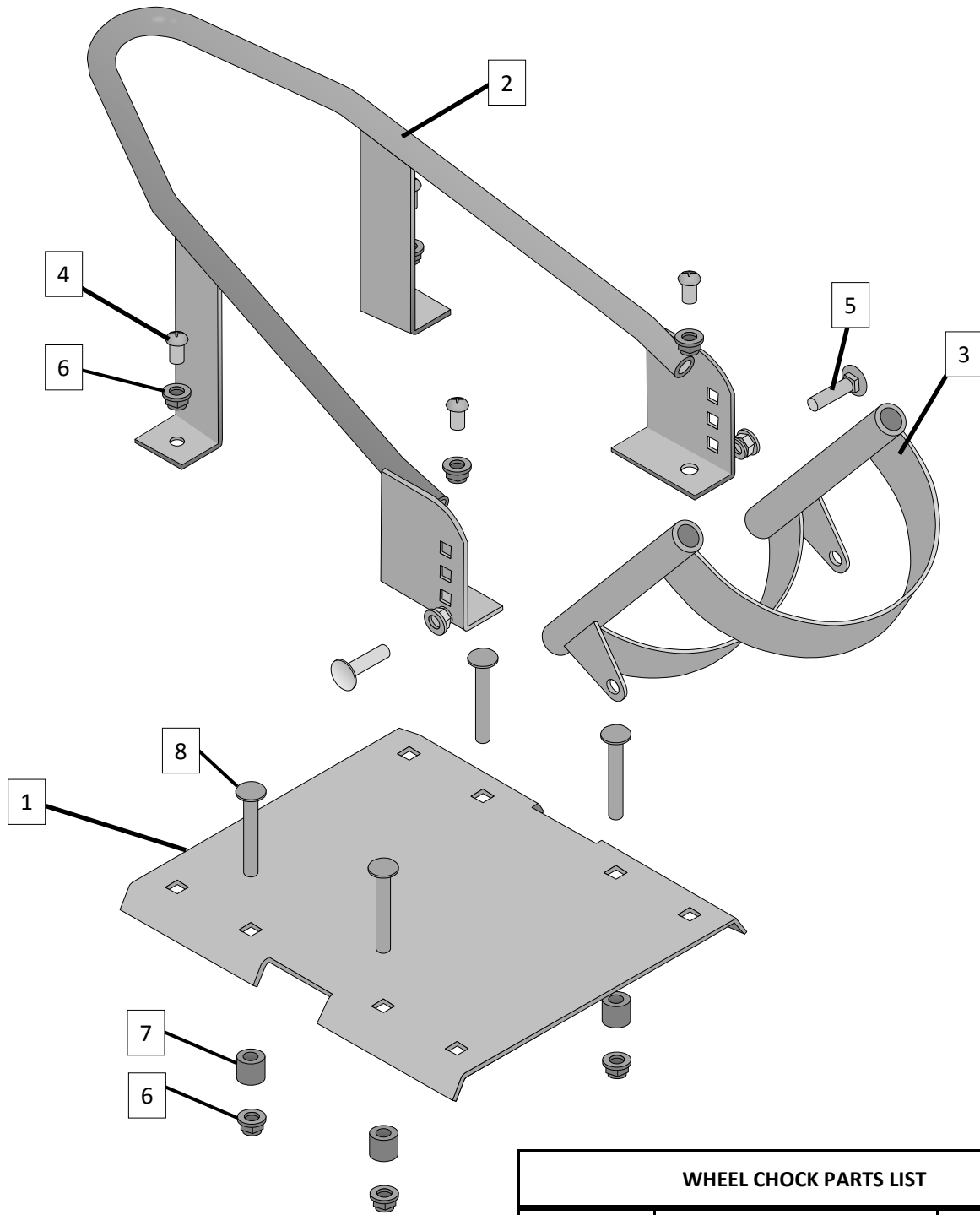

WHEEL CHOCK PARTS LIST		
Part No.	Description	QTY
1	Base	1
2	Main Frame	1
3	Pivoting Bracket	1
4	Round Bolt M10 x 20	4
5	Square Neck Bolt M10 x 30	2
6	Flanged Hex Nut M10	10
7	Sleeve	4
8	Square Neck Bolt M10 x 70	4