



OWNER'S MANUAL

MPN(s): T3STBLGST

SKU(s): 400047

UPC(s): 049008266520

PARTS DIAGRAM / EXPLODED VIEW

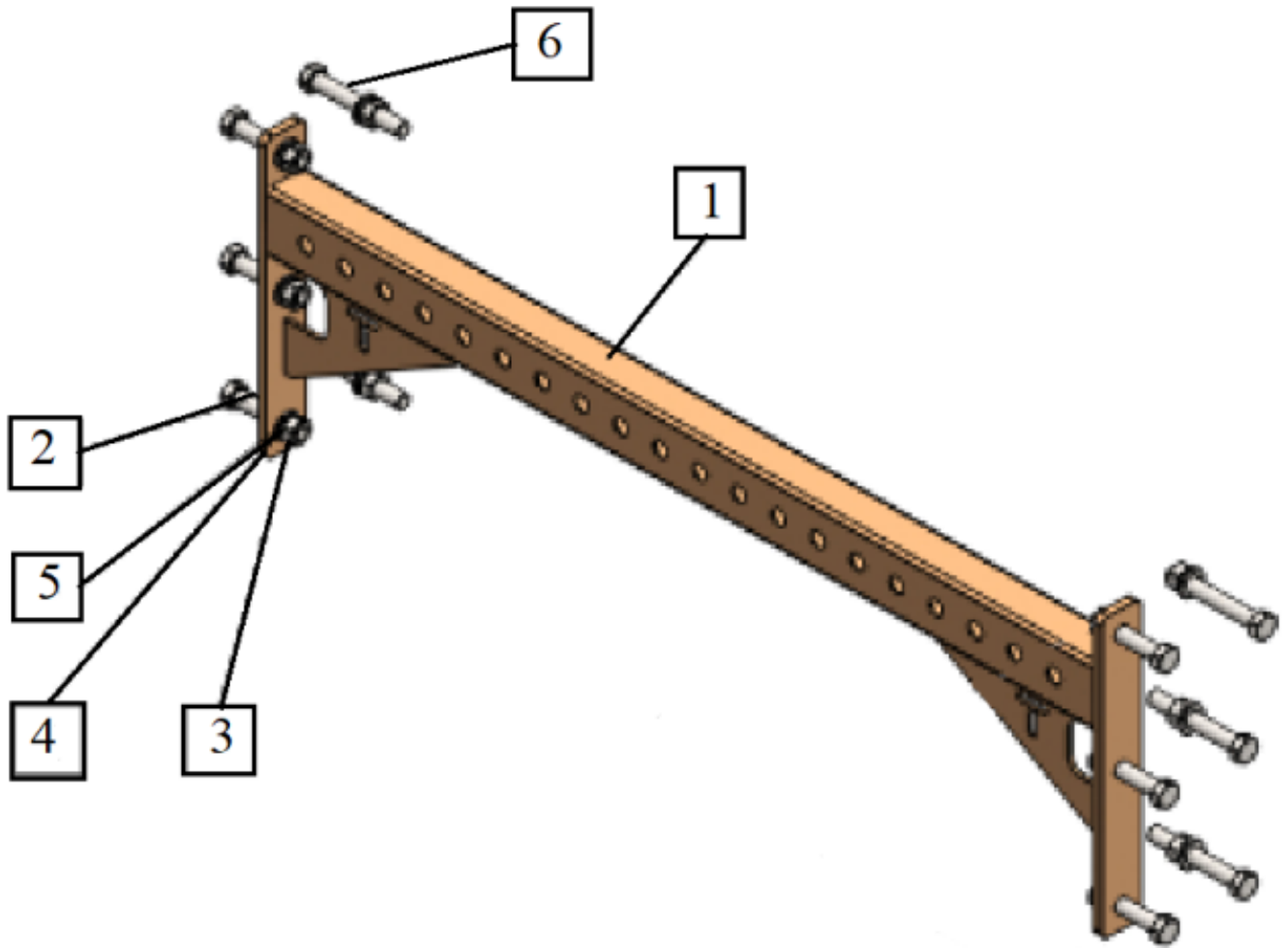

Part Number	Part Description	Quantity
1	Stabilizer Bar	1
2	Hex Bolt M16x80 (T-3)	6
3	Hex Nut M16	6
4	Spring Washer 16	6
5	Flat washer	6
6	Hex Bolt M16x110 (X-3)	6



ASSEMBLY INSTRUCTIONS

Recommendation: The Titan T-3 / X-3 Crossmember can be mounted anywhere on the uprights of your T-3 / X-3 power rack; however, we find most customers prefer to mount it to the top of the back uprights on the T-3 / X-3 power rack.

Two sets of hex bolts are included with the T-3 / X-3 Crossmember to allow for it to be mounted on either the T-3 or X-3 rack. The *Hex Bolt M16x80 (2)* is used when mounting to the T-3 rack, and the *Hex Bolt M16x110 (6)* is used when mounting to the X-3 rack.

1. Attach the *Stabilizer Bar (1)* to the T-3 Power Rack:

Hardware is provided to attach your Titan T-3 / X-3 Crossmember to a Titan T-3 power rack. To secure to the rack, choose the preferred holes on the uprights of your T-3 power rack. Then, assemble the *Stabilizer Bar (1)* to the top hole of those preferred upright holes using the following hardware: *Hex Bolt M16x80 (2)*, then *Flat Washer (5)*, then push the bolt through the upright of your rack. Finally, secure the bolt on the other side of your upright using the *Spring Washer 16 (4)* and *Hex Nut M16 (3)*.

Repeat this process for connecting your *Stabilizer Bar (1)* to the top hole of the other side of your Titan T-3 power rack, then the four lower holes on your chosen section. Complete the assembly by tightening down all six of the *Hex Nut M16s (3)*.

2. Attach the *Stabilizer Bar (1)* to the X-3 Power Rack:

Hardware is provided to attach your Titan T-3 / X-3 Crossmember to a Titan X-3 power rack. To secure to the rack, choose the preferred holes on the uprights of your X-3 power rack. Then, assemble the *Stabilizer Bar (1)* to the top hole of those preferred upright holes using the following hardware: *Hex Bolt M16x110 (6)*, then *Flat Washer (5)*, then push the bolt through the upright of your rack. Finally, secure the bolt on the other side of your upright using the *Spring Washer 16 (4)* and *Hex Nut M16 (3)*.

Repeat this process for connecting your *Stabilizer Bar (1)* to the top hole of the other side of your Titan X-3 power rack, then the four lower holes on your chosen section. Complete the assembly by tightening down all six of the *Hex Nut M16s (3)*.





This concludes the T3STBLGST Owner's Manual.

If applicable to your product, make sure to tighten all nut-and-bolt combinations before use.

Enjoy!

DISCLAIMER

This equipment must be used with care by capable and competent individuals under supervision, if necessary.

The use of any fitness equipment, including this one, involves the potential risk of injury. You accept and assume full responsibility for any and all injuries, damages (both economic and non-economic), and losses of any type, which may occur, and you fully and forever release and discharge Titan, its insurers, employees, officers, directors, associates, and agents from any and all claims, demands, damages, rights of action, or causes of action, present or future, whether the same be known or unknown, anticipated, or unanticipated, resulting from or arising out of the use of said equipment.

TITAN MAKES NO WARRANTY WHATSOEVER WITH RESPECT TO THE EQUIPMENT, INCLUDING ANY WARRANTY OF MERCHANTABILITY OR WARRANTY OF FITNESS FOR A PARTICULAR PURPOSE, WHETHER EXPRESS OR IMPLIED BY LAW, COURSE OF DEALING, COURSE OF PERFORMANCE, USAGE OF TRADE OR OTHERWISE. BUYER ASSUMES ALL LIABILITY IN USE OF THE EQUIPMENT.

NEED HELP?

CONTACT US FIRST.

1 (800) 605-8241

info@titandistributorsinc.com / www.titan.fitness

Business Hours: Monday–Friday • 8:00 a.m.–5:00 p.m. (CT)

