



**TITAN**  
*FITNESS*



## OWNER'S MANUAL

---

**MPN(s):** X3BSTND

**SKU(s):** 401155

**UPC(s):** 840009212161

# PARTS DIAGRAM / EXPLODED VIEW

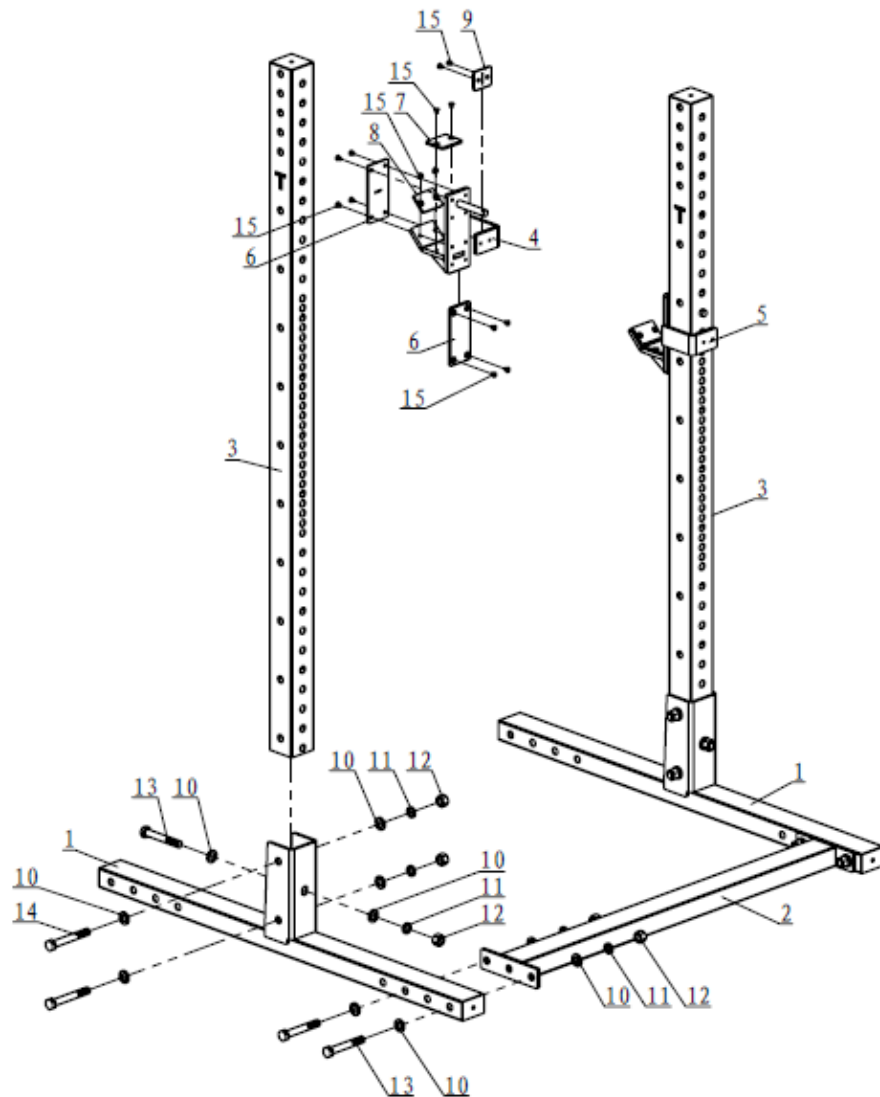

KEY	BOX	DESCRIPTION	QTY	KEY	BOX	DESCRIPTION	QT
(1)	1	Base Frame	2	(9)	1	Short Plastic Plate 58*48*5	2
(2)	1	Connecting Frame	1	(10)	1	Flat Washer $\Phi 17 \times \Phi 30 \times 3$	20
(3)	1	Upright Frame	2	(11)	1	Spring Washer $\Phi 16$	10
(4)	1	Left J-Hook	1	(12)	1	M16 Nut	10
(5)	1	Right J-Hook	1	(13)	1	Hex Bolt M16*110	6
(6)	1	Long Plastic Plate 148*68*5	4	(14)	1	Hex Bolt M16*120	4
(7)	1	Plastic Plate 68*58*5	2	(15)	1	Countersunk head screw M6*10	28
(8)	1	Front Plastic Plate 68*48*5	2				



# ASSEMBLY INSTRUCTIONS

---

## STEP 1

Assemble the Base Frame (1) and Connecting Frame (2), using Flat Washer  $\Phi 17*\Phi 30*3$  (10), Spring Washer (11), Nut M16 (12) and Hex Bolt M16\*110 (13).

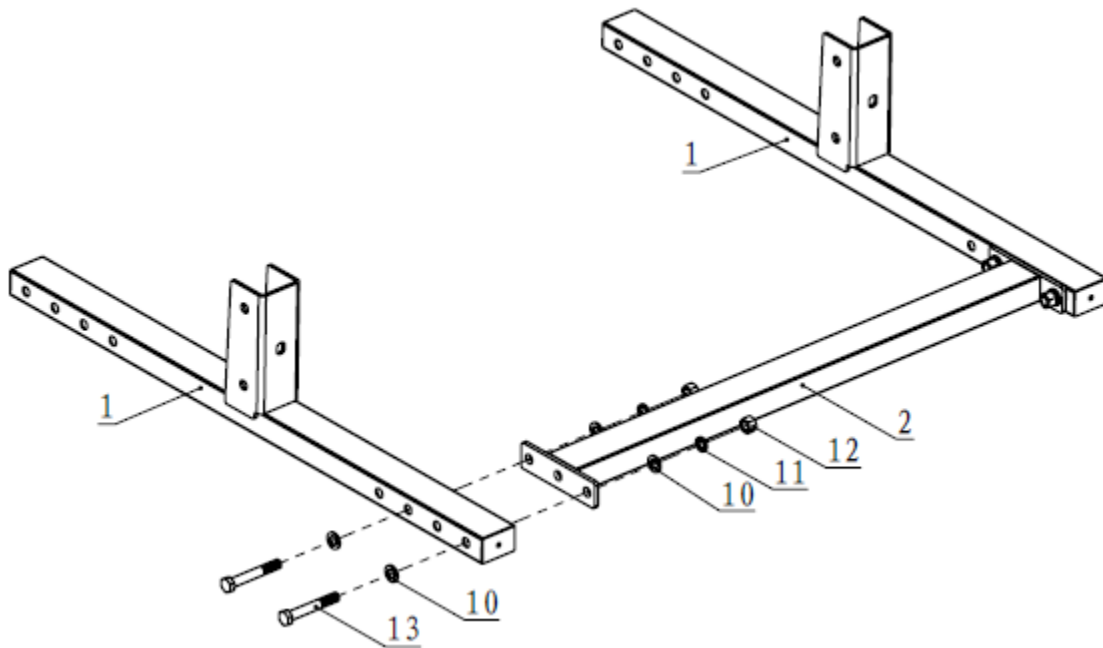

# ASSEMBLY INSTRUCTIONS

---

## STEP 2

Assemble the Upright Frame (3) on the Base Frame (1), using Flat Washer  $\Phi 17*\Phi 30*3$  (10), Spring Washer (11) Nut M16 (12), Hex Bolt M16\*110(13) and Hex Bolt M16\*120 (14).

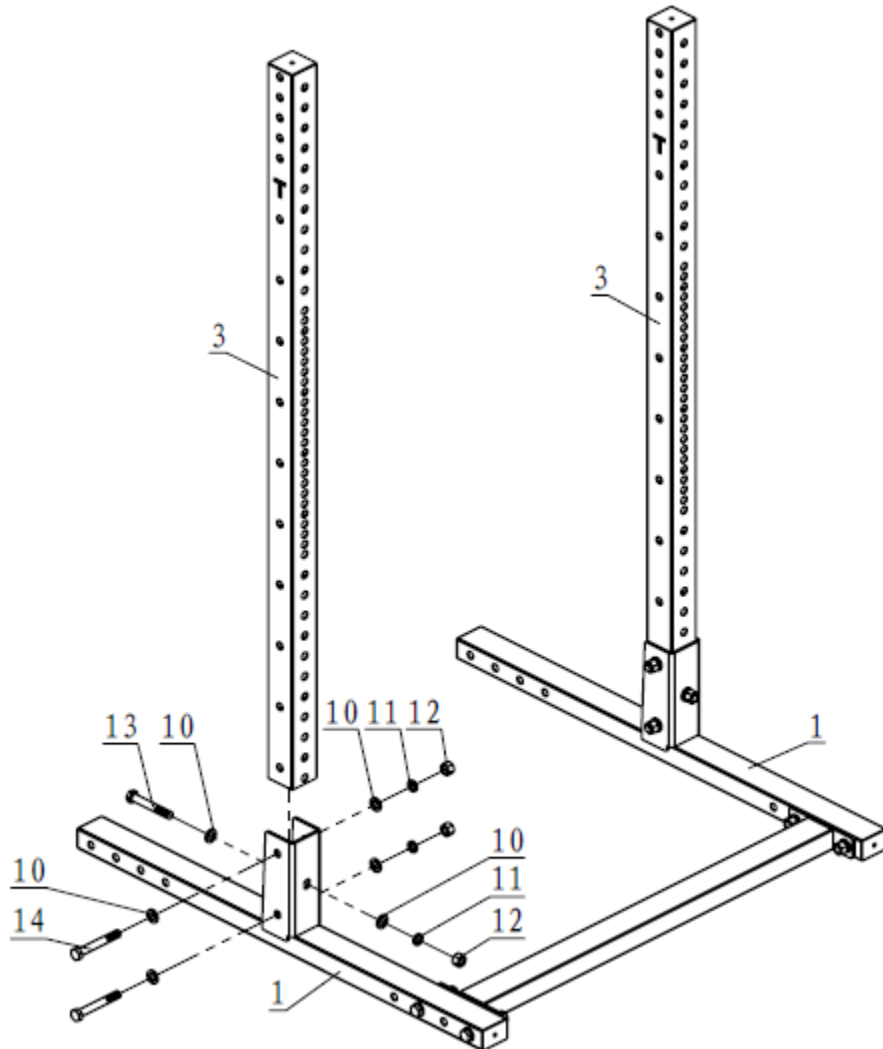

# ASSEMBLY INSTRUCTIONS

---

## STEP 3

Install the Left & Right Barbell Holder (4 & 5) on Upright Frame (3).

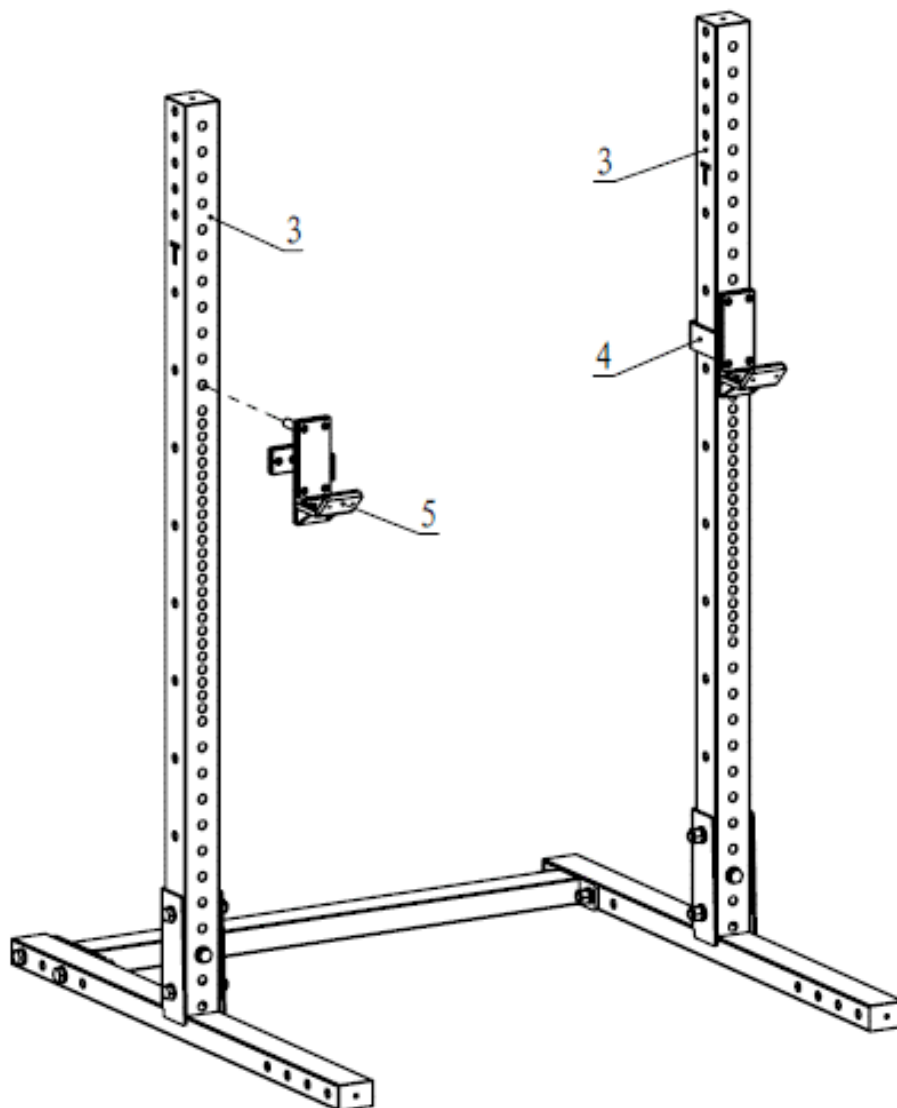



*This concludes the X3BSTND Owner's Manual.  
If applicable to your product, make sure to tighten  
all nut-and-bolt combinations before use.*

*Enjoy!*

### **DISCLAIMER**

This equipment must be used with care by capable and competent individuals under supervision, if necessary.

The use of any fitness equipment, including this one, involves the potential risk of injury. You accept and assume full responsibility for any and all injuries, damages (both economic and non-economic), and losses of any type, which may occur, and you fully and forever release and discharge Titan, its insurers, employees, officers, directors, associates, and agents from any and all claims, demands, damages, rights of action, or causes of action, present or future, whether the same be known or unknown, anticipated, or unanticipated, resulting from or arising out of the use of said equipment.

TITAN MAKES NO WARRANTY WHATSOEVER WITH RESPECT TO THE EQUIPMENT, INCLUDING ANY WARRANTY OF MERCHANTABILITY OR WARRANTY OF FITNESS FOR A PARTICULAR PURPOSE, WHETHER EXPRESS OR IMPLIED BY LAW, COURSE OF DEALING, COURSE OF PERFORMANCE, USAGE OF TRADE OR OTHERWISE. BUYER ASSUMES ALL LIABILITY IN USE OF THE EQUIPMENT.

**NEED HELP?**

**CONTACT US FIRST.**

**1 (800) 605-8241**

[info@titandistributorsinc.com](mailto:info@titandistributorsinc.com) / [www.titan.fitness](http://www.titan.fitness)

**Business Hours: Monday–Friday • 8:00 a.m.–5:00 p.m. (CT)**

