



TITAN
FITNESS



OWNER'S MANUAL

MPN(s): X3BDUP80 - X3BDEXT24, X3BDUP80 - X3BDEXT36, X3BDUP90 - X3BDEXT24, X3BDUP90 - X3BDEXT36

SKU(s): 401404, 401406, 401405, 401407

UPC(s): 840009217067, 840009217081, 840009217074, 840009217098

X3BDEXT24 PARTS DIAGRAM

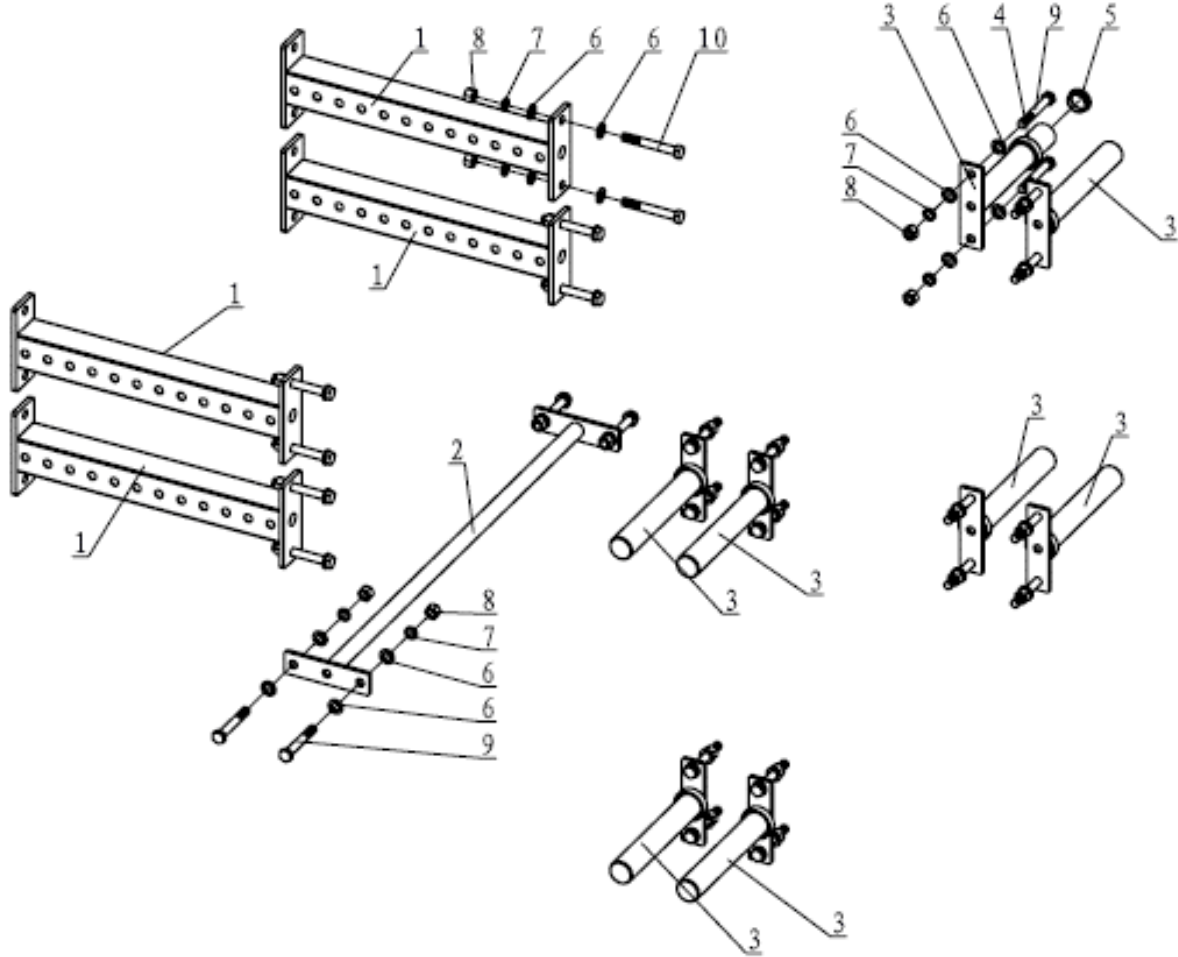

KEY	BOX	DESCRIPTION	QTY	KEY	BOX	DESCRIPTION	QT
(1)	1	24" Connecting Frame	4	(6)	1	Flat Washer $\Phi 17 * \Phi 30 * 3$	56
(2)	1	Pull Up Bar	1	(7)	1	Spring Washer $\Phi 16$	28
(3)	1	Weight Plate Holder	8	(8)	1	M16 Nut	28
(4)	1	Rubber Cushion	8	(9)	1	Hex Bolt M16*110	20
(5)	1	$\Phi 48$ End Cap	8	(10)	1	Hex Bolt M16*120	8



ASSEMBLY INSTRUCTIONS

STEP 1

1. Install the 24" Connecting Frame (1) on the Upright frame (12), using Flat Washer $\Phi 17*\Phi 30*3(6)$, M16 Nut (8), $\Phi 16$ Spring Washer (7), and Hex Bolt M16*110(9).
2. Connect the 24" Connecting Frame (2) and the Upright frame, using Flat Washer $\Phi 17*\Phi 30*3(6)$, M16 Nut (8), $\Phi 16$ Spring Washer (7), and Hex Bolt M16*120(10).
3. Assemble the Pull Up Bar (2) on the Upright Frame, using Flat Washer $\Phi 17*\Phi 30*3(6)$, M16 Nut (8), $\Phi 16$ Spring Washer (7), and Hex Bolt M16*110(9).

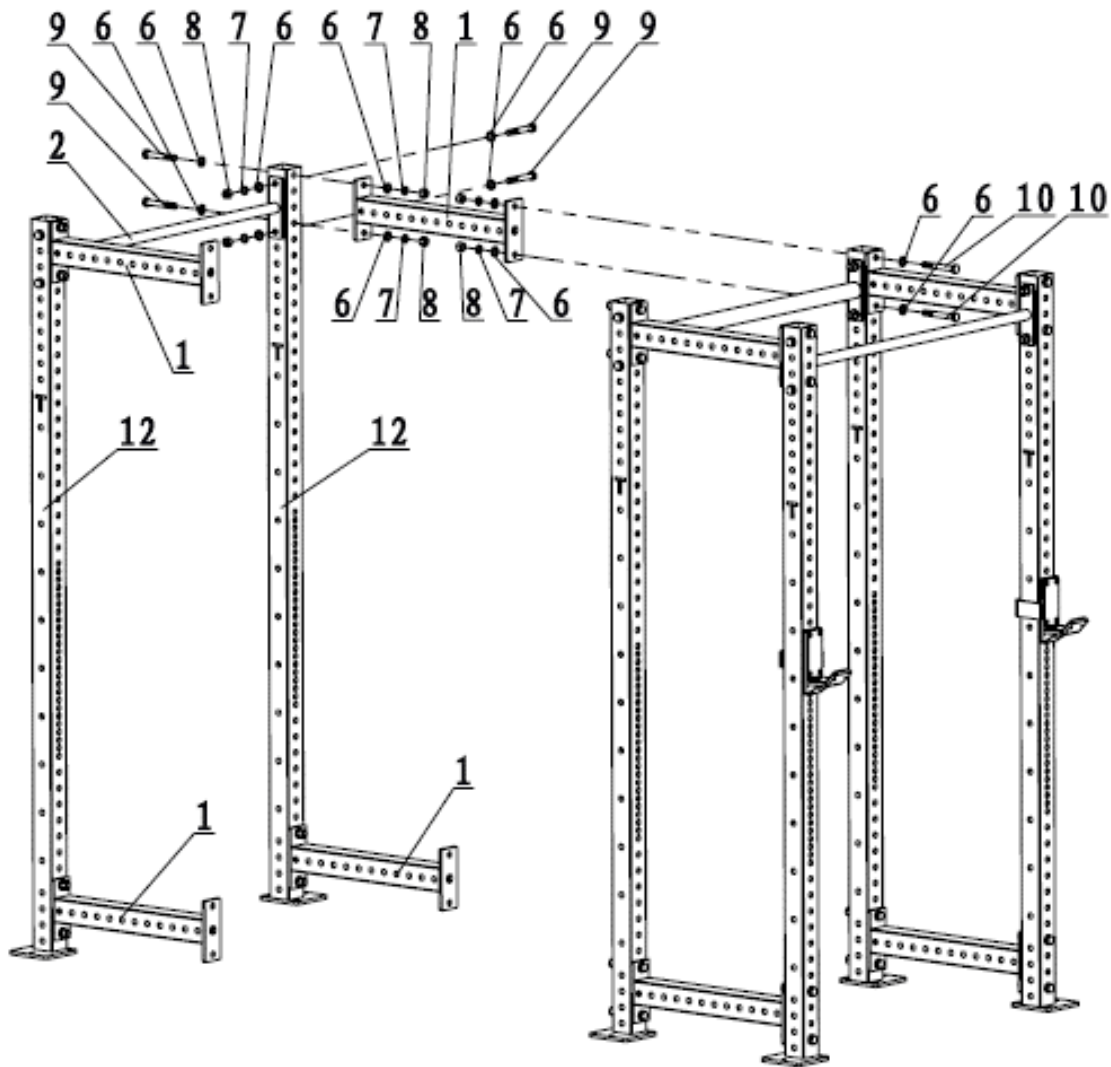

ASSEMBLY INSTRUCTIONS

STEP 2

Assemble the Weight Plate Holder (3) on the Upright Frame, using Flat Washer $\Phi 17 \times \Phi 30 \times 3$ (6), M16 Nut (8), $\Phi 16$ Spring Washer (7), and Hex Bolt M16*110(9).

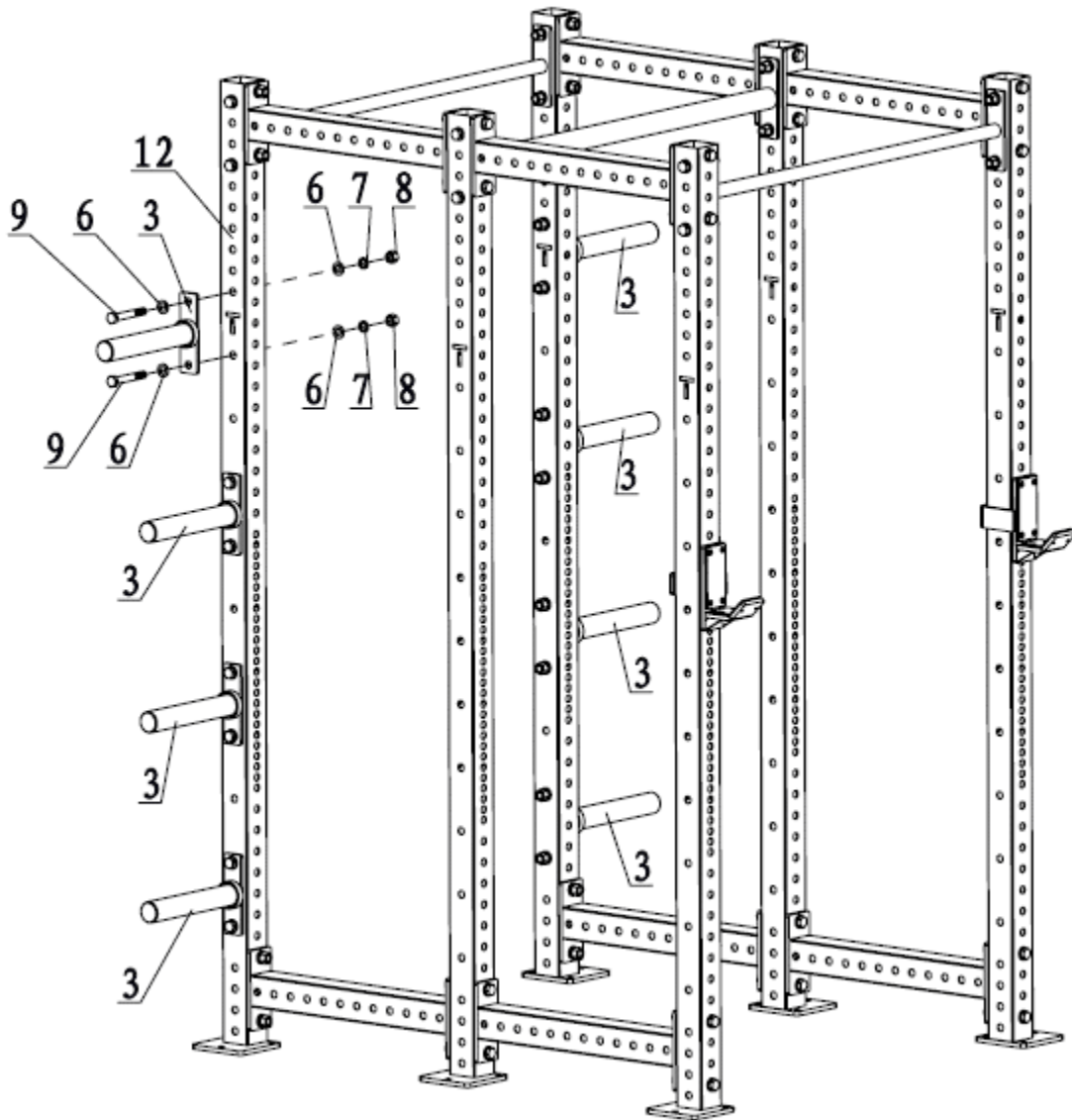

X3BDEXT36 PARTS DIAGRAM

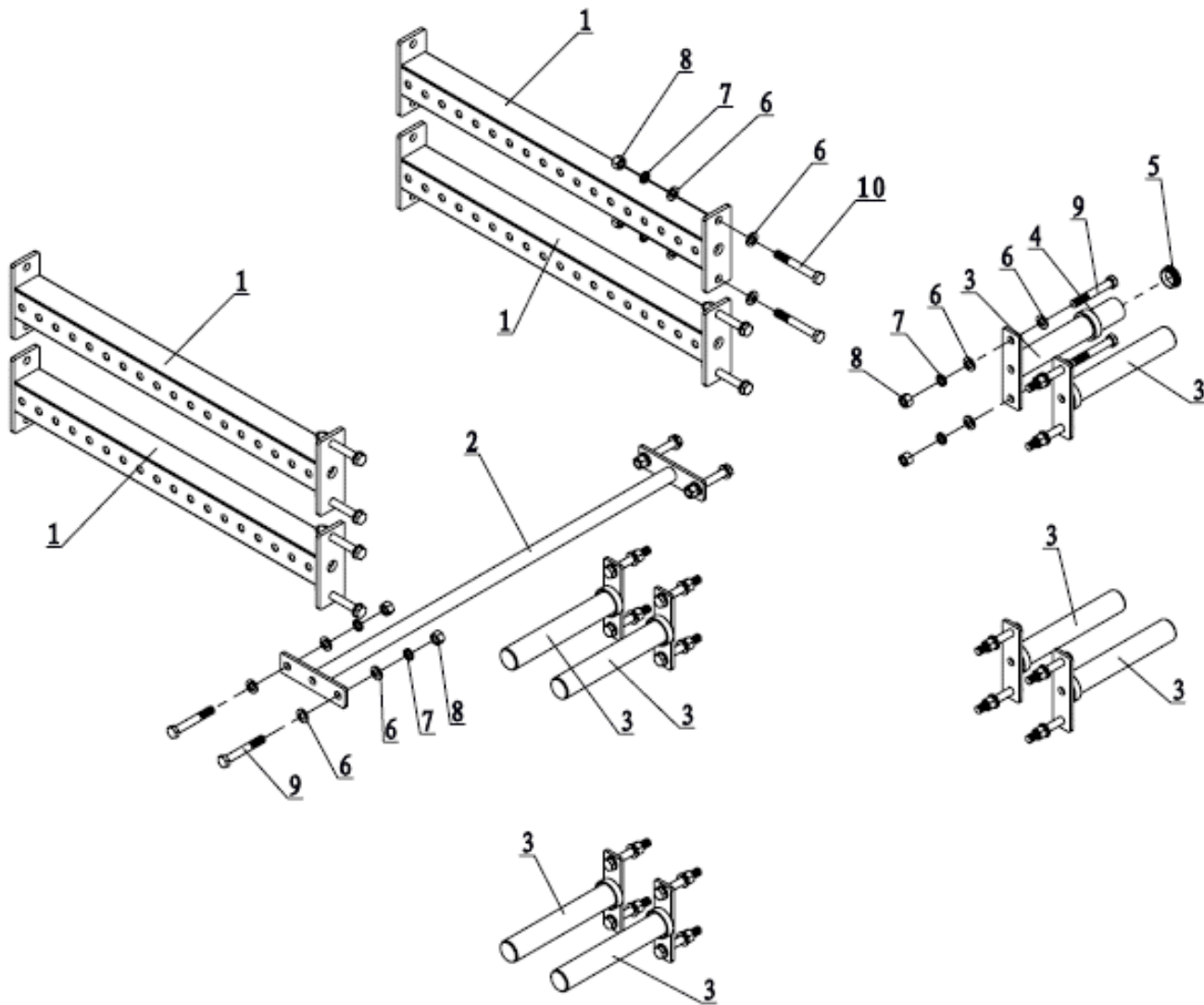

KEY	BOX	DESCRIPTION	QTY	KEY	BOX	DESCRIPTION	QT
(1)	1	36" Connecting Frame	4	(6)	1	Flat Washer $\Phi 17 * \Phi 30 * 3$	56
(2)	1	Pull Up Bar	1	(7)	1	Spring Washer $\Phi 16$	28
(3)	1	Weight Plate Holder	8	(8)	1	M16 Nut	28
(4)	1	Rubber Cushion	8	(9)	1	Hex Bolt M16*110	20
(5)	1	$\Phi 48$ End Cap	8	(10)	1	Hex Bolt M16*120	8



ASSEMBLY INSTRUCTIONS

STEP 1

4. Install the 24" Connecting Frame (1) on the Upright frame (12), using Flat Washer $\Phi 17*\Phi 30*3(6)$, M16 Nut (8), $\Phi 16$ Spring Washer (7), and Hex Bolt M16*110(9).
5. Connect the 24" Connecting Frame (2) and the Upright frame, using Flat Washer $\Phi 17*\Phi 30*3(6)$, M16 Nut (8), $\Phi 16$ Spring Washer (7), and Hex Bolt M16*120(10).
6. Assemble the Pull Up Bar (2) on the Upright Frame, using Flat Washer $\Phi 17*\Phi 30*3(6)$, M16 Nut (8), $\Phi 16$ Spring Washer (7), and Hex Bolt M16*110(9).

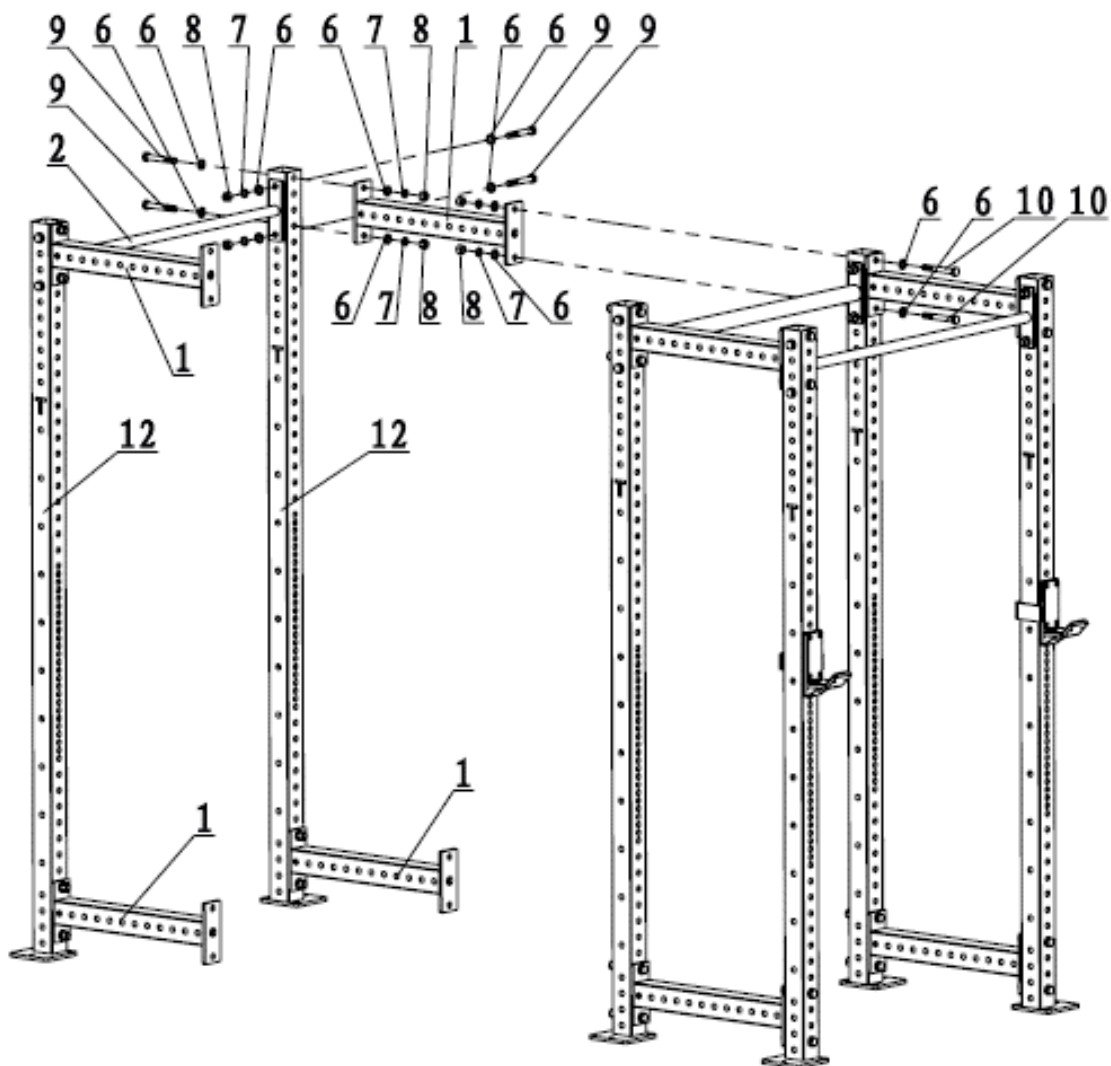

ASSEMBLY INSTRUCTIONS

STEP 2

Assemble the Weight Plate Holder (3) on the Upright Frame, using Flat Washer $\Phi 17 \times \Phi 30 \times 3$ (6), M16 Nut (8), $\Phi 16$ Spring Washer (7), and Hex Bolt M16*110(9).

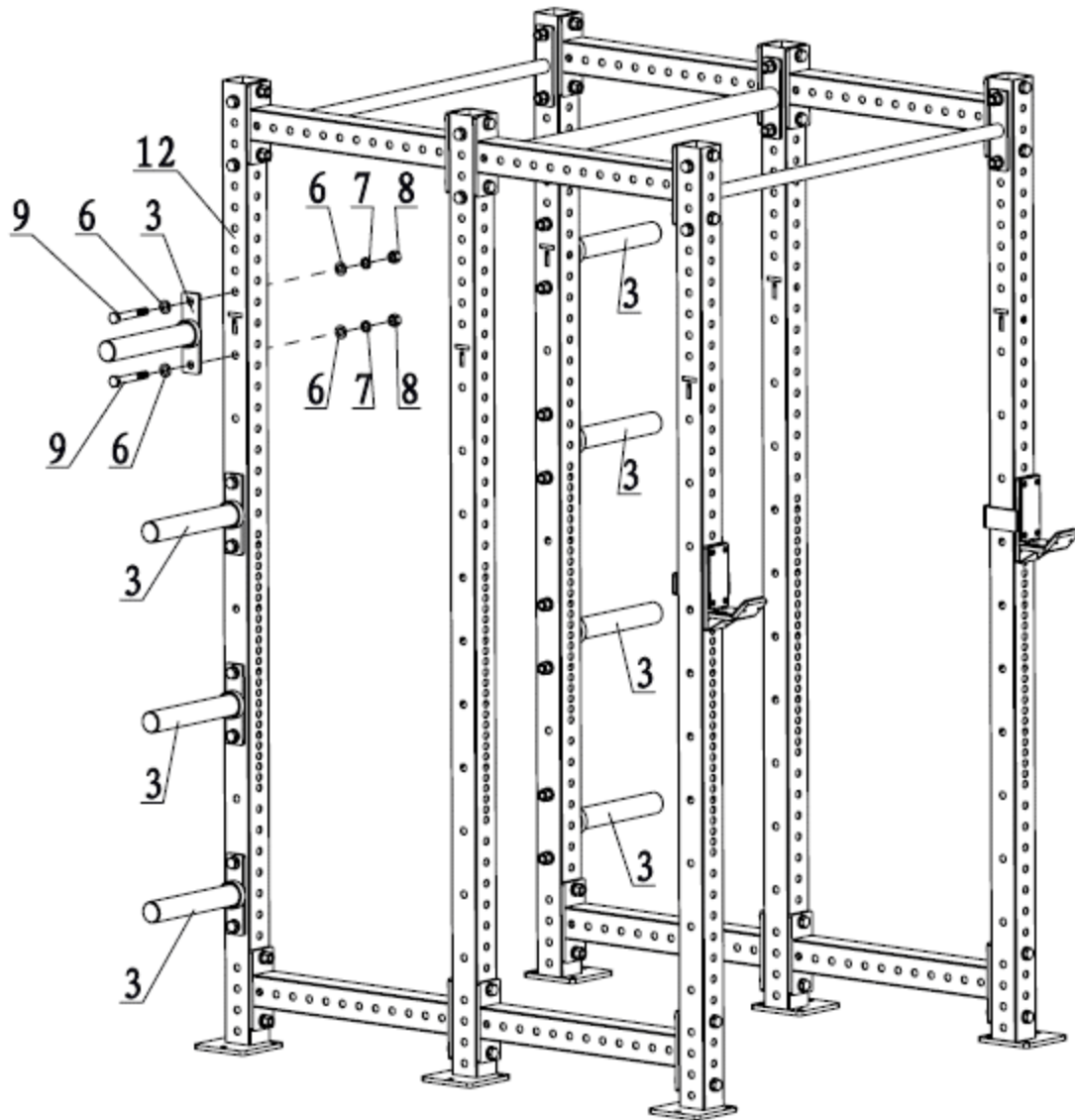

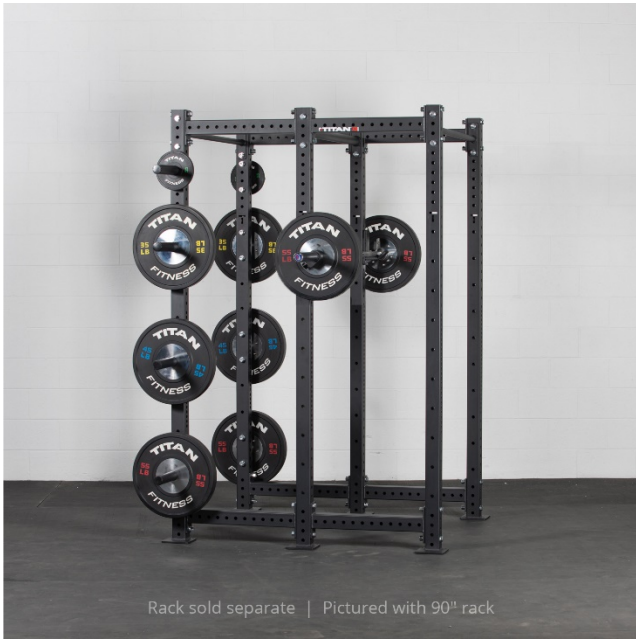

*This concludes the X3SERIES-BDEXT
Owner's Manual.*

*If applicable to your product, make sure to tighten
all nut-and-bolt combinations before use.*

Enjoy!

DISCLAIMER

This equipment must be used with care by capable and competent individuals under supervision, if necessary.

The use of any fitness equipment, including this one, involves the potential risk of injury. You accept and assume full responsibility for any and all injuries, damages (both economic and non-economic), and losses of any type, which may occur, and you fully and forever release and discharge Titan, its insurers, employees, officers, directors, associates, and agents from any and all claims, demands, damages, rights of action, or causes of action, present or future, whether the same be known or unknown, anticipated, or unanticipated, resulting from or arising out of the use of said equipment.

TITAN MAKES NO WARRANTY WHATSOEVER WITH RESPECT TO THE EQUIPMENT, INCLUDING ANY WARRANTY OF MERCHANTABILITY OR WARRANTY OF FITNESS FOR A PARTICULAR PURPOSE, WHETHER EXPRESS OR IMPLIED BY LAW, COURSE OF DEALING, COURSE OF PERFORMANCE, USAGE OF TRADE OR OTHERWISE. BUYER ASSUMES ALL LIABILITY IN USE OF THE EQUIPMENT.

NEED HELP?

CONTACT US FIRST.

1 (800) 605-8241

info@titandistributorsinc.com / www.titan.fitness

Business Hours: Monday–Friday • 8:00 a.m.–5:00 p.m. (CT)

