



X3FOLD

MPNs: X3SHUPFPWR-2X3FPWR_S
X3UPFPWR-2X3FPWR_S
X3SHUPFPWR-4X3FPWR_S
X3UPFPWR-4X3FPWR_S

Parts Diagrams

X3SHUPFPWR - 2X3FPWR S

X3SHUPFPWR

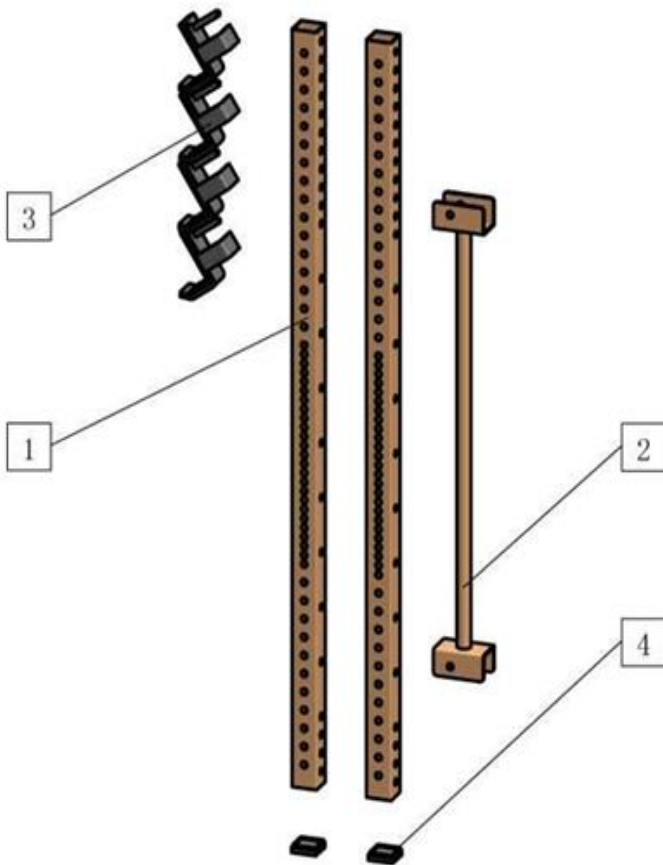

- | | |
|---------------------------------|----|
| 1. Upright Post | x2 |
| 2. Pullup Bar | x1 |
| 3. J-hook | x4 |
| 4. Upright Post Bottom Tube Cap | x2 |

2X3FPWR_S

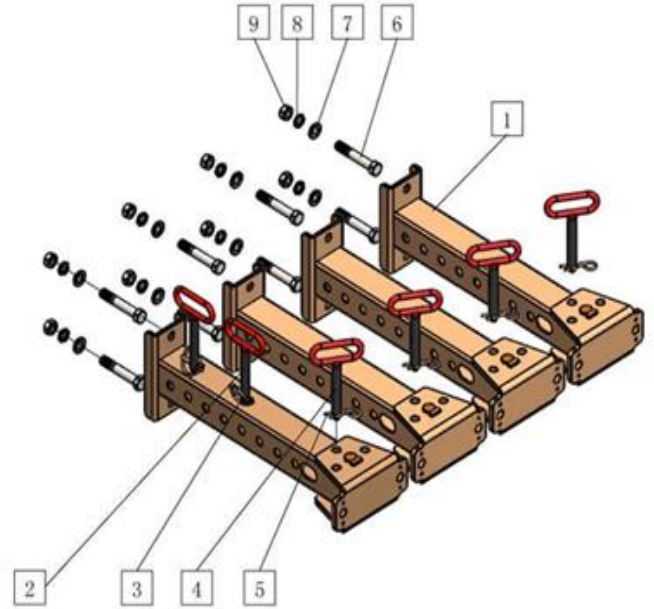

- | | |
|---------------------------|----|
| 1. 21.5" Side Brace | x4 |
| 2. Pullup Bar Pin Ø16x100 | x2 |
| 3. Pin Lock | x2 |
| 4. Hinge Pin Ø17x100 | x4 |
| 5. Cotter Pin | x4 |
| 6. Hexa Bolt M16x100 | x8 |
| 7. Flat Washer 16 | x8 |
| 8. Spring Washer 16 | x8 |
| 9. Hexa Nut M16 | x8 |

X3UPFPWR - 2X3FPWR S

X3UPFPWR

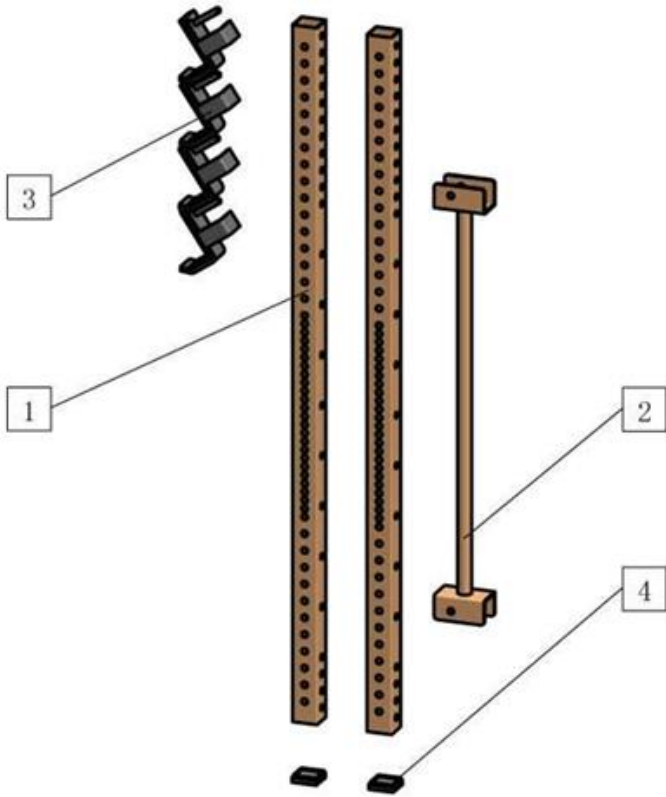

- | | |
|---------------------------------|----|
| 1. Upright Post | x2 |
| 2. Pullup Bar | x1 |
| 3. J-hook | x4 |
| 4. Upright Post Bottom Tube Cap | x2 |

2X3FPWR_S

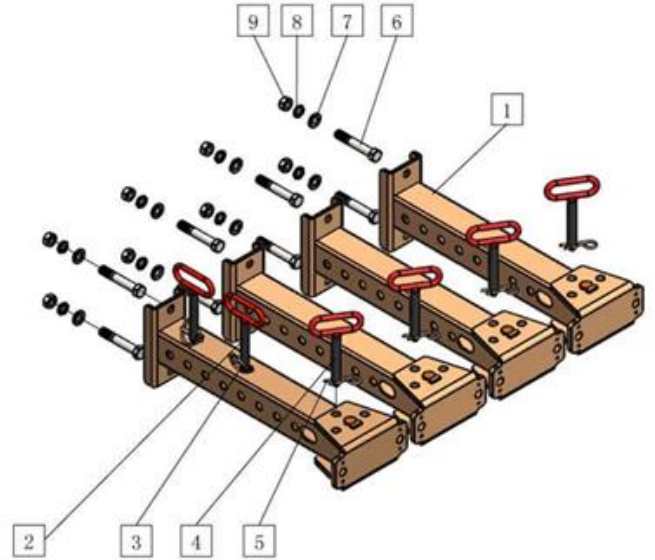

- | | |
|---------------------------|----|
| 1. 21.5" Side Brace | x4 |
| 2. Pullup Bar Pin Ø16x100 | x2 |
| 3. Pin Lock | x2 |
| 4. Hinge Pin Ø17x100 | x4 |
| 5. Cotter Pin | x4 |
| 6. Hex Bolt M16x100 | x8 |
| 7. Flat Washer 16 | x8 |
| 8. Spring Washer 16 | x8 |
| 9. Hex Nut M16 | x8 |

X3UPFPWR - 4X3FPWR S

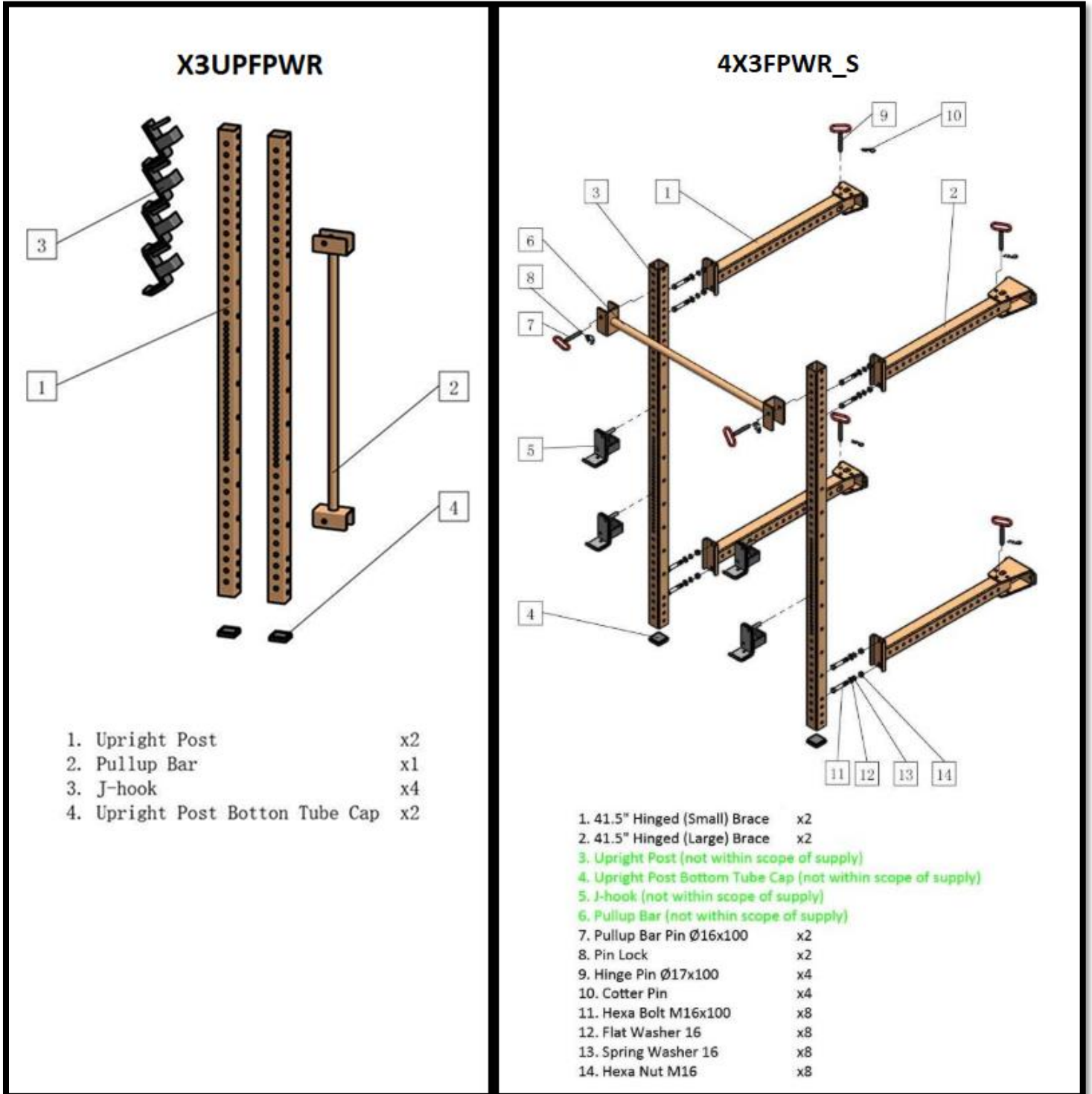

X3SHUPFPWR - 4X3FPWR S

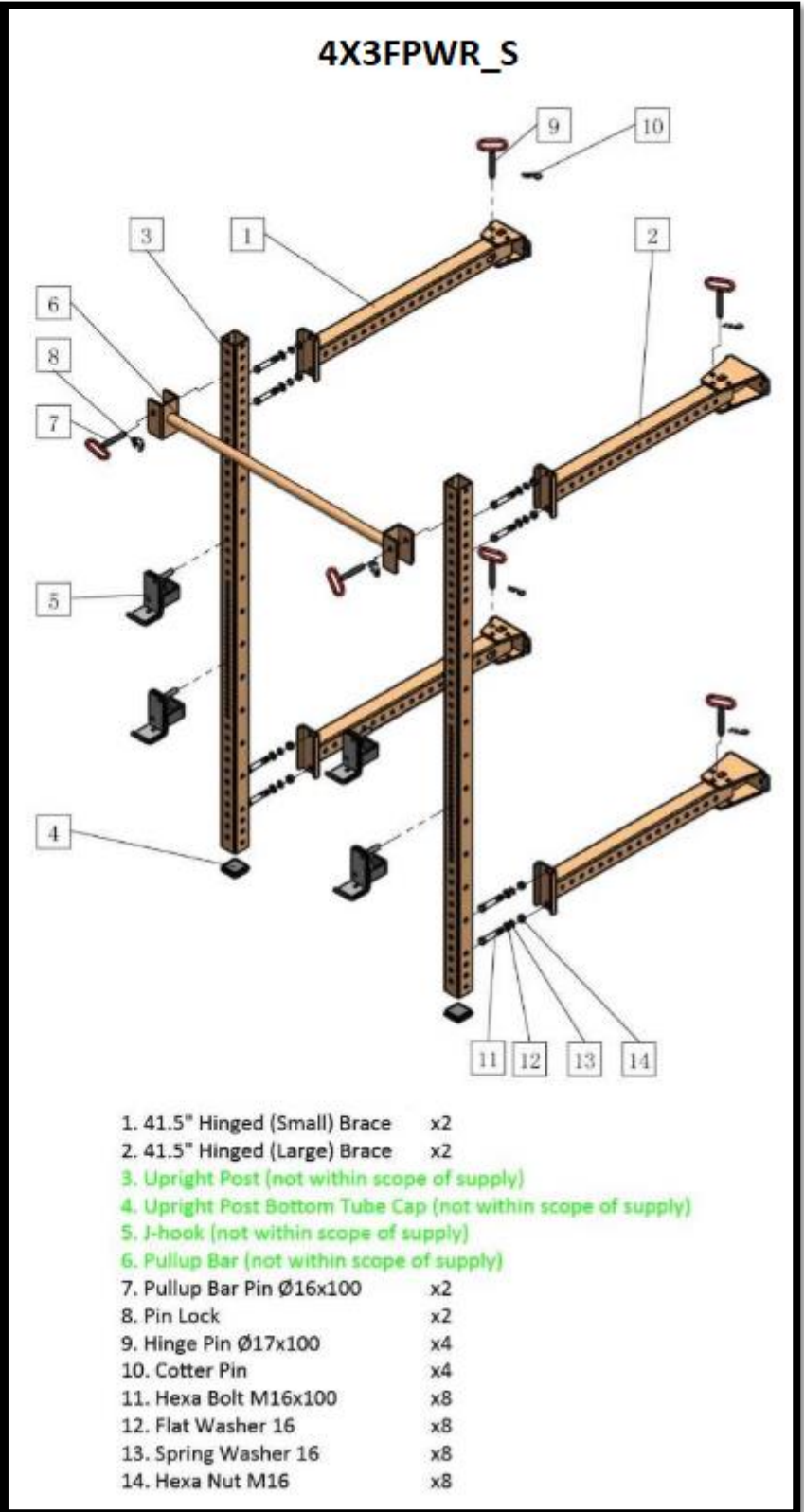
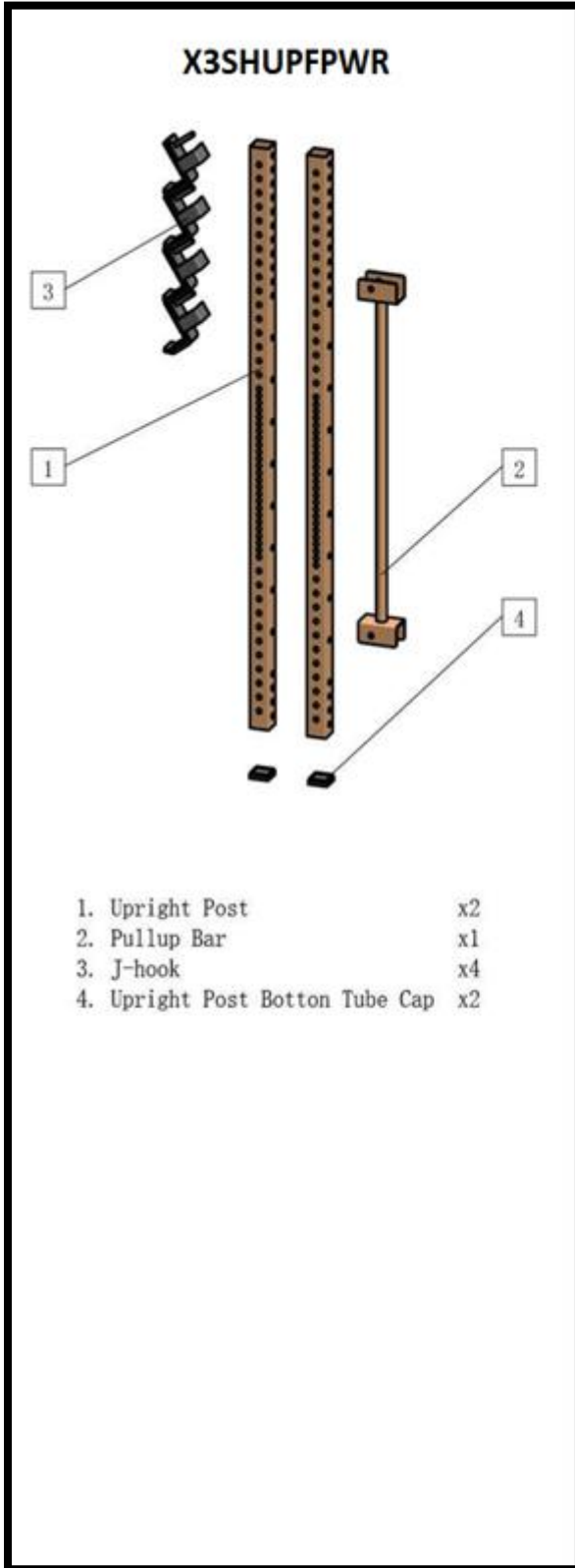

NEED HELP?

CONTACT US FIRST.

1 (800) 605-8241

info@titandistributorsinc.com / www.titan.fitness

Business Hours: Monday–Friday • 8:00 a.m.–5:00 p.m. (CT)