

72SDBCKTv2

72SDBCKTv2, 72SDBCKT_BELT

114240, 114239



Operator's Manual



Read the Operator's Manual entirely. When you see this symbol, the subsequent instructions and warnings are serious follow without exception. Your life and the lives of others depend on it!

PARTS DIAGRAM / EXPLODED VIEW

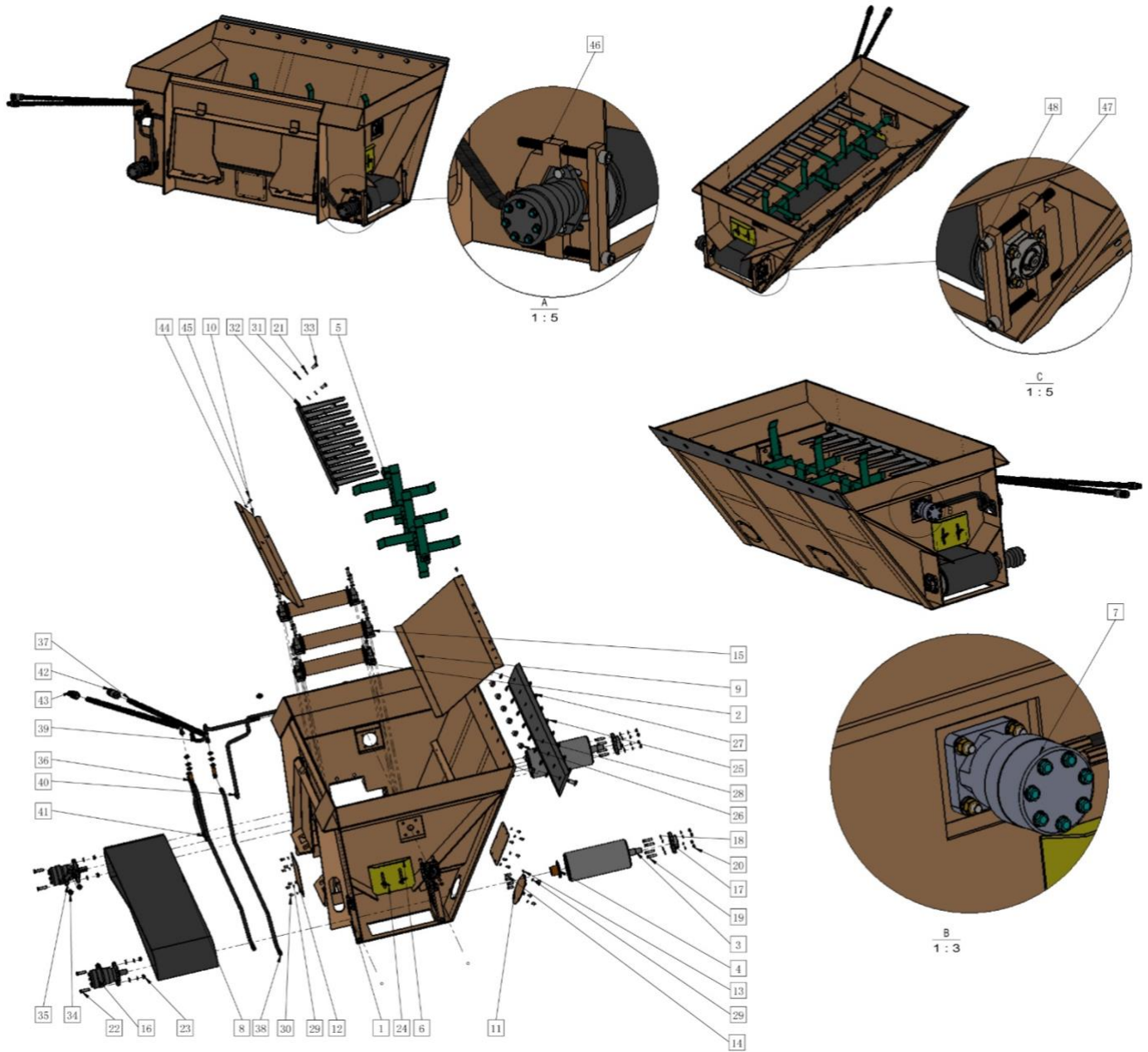

PARTS DIAGRAM / EXPLODED VIEW

KEY	DESCRIPTION	QTY
(1)	DISCHARGE BUCKET	1
(2)	CONVEYOR BELT TENSION ROLLER	3
(3)	CONVEYOR BELT MAIN ROLLER	2
(4)	ROLLER FLANGE COUPLER	2
(5)	ROTARY AGITATOR	1
(6)	DISCHARGE GATE	2
(7)	AGITATOR HYDRAULIC MOTOR (BR100)	1
(8)	CONVEYOR BELT	1
(9)	SLIDING PLATE - LEFT	1
(10)	SLIDING PLATE - RIGHT	1
(11)	BUCKET ROUND COVER PLATE	1
(12)	MAINTENANCE GATE	2
(13)	SPRING WASHER 10	24
(14)	HEXA BOLT M10X25	8
(15)	BEARING-1 (UCP205)	6
(16)	CONVEYOR BELT HYDRAULIC MOTOR (BR160)	2
(17)	BEARING-2 (UCFU205)	3
(18)	FLAT WASHER 10	28
(19)	HEXA BOLT M10X45	28
(20)	HEXA NUT M10	16
(21)	SPRING WASHER 12	9
(22)	HEXA BOLT M12X45HD	4
(23)	HEXA NUT M12	4
(24)	BUTTERFLY NUT M10X1.5	4
(25)	COUNTERSUNK HEXA BOLT M16X45	9
(26)	HEXA CAP NUT M16	9
(27)	72" CUTTING EDGE	1
(28)	SPRING WASHER 16	9

(29)	SPRING WASHER 8	15
(30)	COUNTERSUNK HEXA ROUND HEAD BOLT M8X16	15
(31)	FLAT WASHER 12	7
(32)	STATIONARY RACK	1
(33)	HEXA BOLT M12X25	5
(34)	HOSE CONNECTOR	6
(35)	Φ18 GASKET	6
(36)	T-CONNECTOR	2
(37)	MAIN HOSE	2
(38)	OIL HOSE-1	2
(39)	OIL HOSE-2	1
(40)	OIL HOSE-3	1
(41)	OIL HOSE	
(42)	FLAT FACE COUPLER – FEMALE	1
(43)	FLAT FACE COUPLER – MALE	1
(44)	FLAT WASHER 8	6
(45)	HEXA BOLT M8X16	6
(46)	BELT TENSION ADJUSTMENT BRACKET - LEFT	1
(47)	BELT TENSION ADJUSTMENT BRACKET - RIGHT	1
(48)	HEXA FULL THREAD BOLT M16X100	4

ASSEMBLY INSTRUCTIONS

— PRODUCT SOLD AS FULL ASSEMBLY WITH NO INSTALLATION REQUIRED BY CUSTOMER.

INSTRUCTIONS FOR CONVEYOR BELT REPLACEMENT

TAKING OFF OLD CONVEYOR BELT

STEP 1 - TAKE OFF STATIONARY RACK

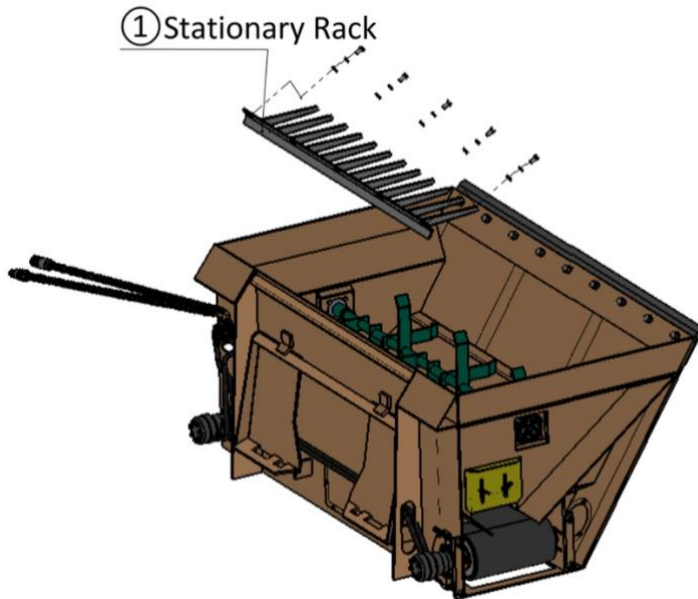

Disassemble Stationary Rack by removing hardware.

STEP 2 - TAKE OFF AGITATOR MOTOR AND SLIDING PLATES

- Disassemble ① Agitator Motor
- Disassemble ② Rotary Agitator
- Disassemble ③ Sliding Plate
- Right and ④ Sliding Plate - Left
- Step 3 - Take off Conveyor Belt

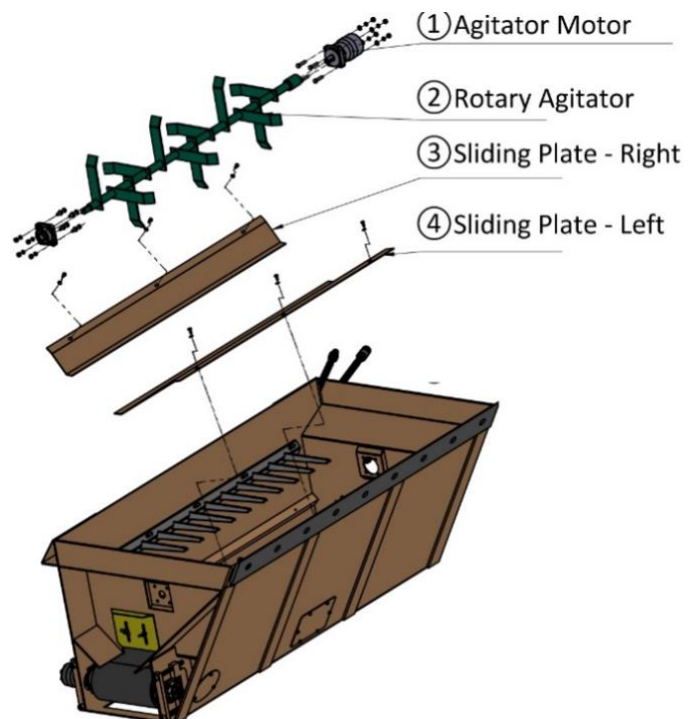

INSTRUCTIONS FOR CONVEYOR BELT REPLACEMENT

- Disassemble ① Tension Rollers
- Disassemble ② Tension Adjustment Bracket
- Take off ③ Belt Motor - Left
- Take off ④ Flange Coupler - Left
- Take off ⑤ Main Roller - Left
- Take off ⑥ Conveyor Belt Motor - Right
- Take off ⑦ Flange Coupler - right
- Take off ⑧ Main Roller - Right
- Take off ⑨ Bearing
- Take off ⑩ Conveyor Belt

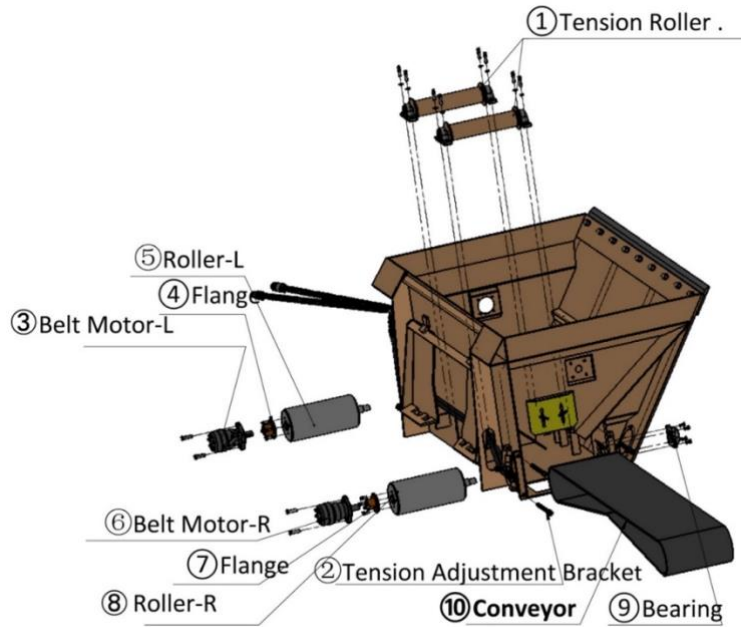

2. PUTTING ON REPLACEMENT CONVEYOR BELT

STEP 1 - PUT ON CONVEYOR BELT AND ROLLERS

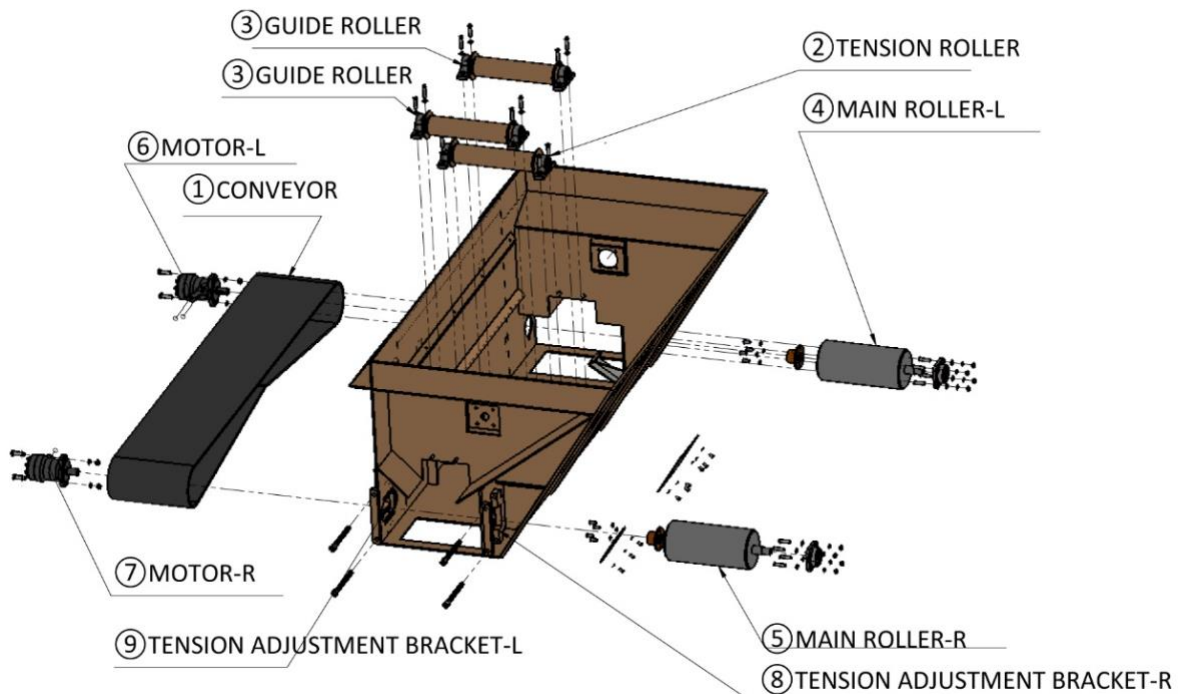

INSTRUCTIONS FOR CONVEYOR BELT REPLACEMENT

- Place ① CONVEYOR BELT at bottom of the bucket
- Install the ② TENSION ROLLER at center
- Install the ③ GUIDE ROLLER on both sides of the ② TENSION ROLLER
- Install the ④ MAIN ROLLER-LEFT on the left end
- Install the ⑤ MAIN ROLLER-RIGHT on the right end
- Install the ⑥ CONVEYOR BELT MOTOR – LEFT on the left side
- Install the ⑦ CONVEYOR BELT MOTOR – RIGHT on the right side
- Install the ⑧ TENSION ADJUSTMENT BRACKET-RIGHT on the right side
- Install the ⑨ TENSION ADJUSTMENT BRACKET-LEFT on the left side
- Adjust the tension of the conveyor belt with the bolts on the left and right TENSION ADJUSTMENT BRACKET

STEP 2 – PUT ON ROTARY AGITATOR AND SLIDE PLATES

- Install the ① SLIDING PLATE-LEFT on the left side
- Install the ② SLIDING PLATE-RIGHT on the right side
- Put on the ③ ROTARY AGITATOR
- Install the ④ AGITATOR MOTOR

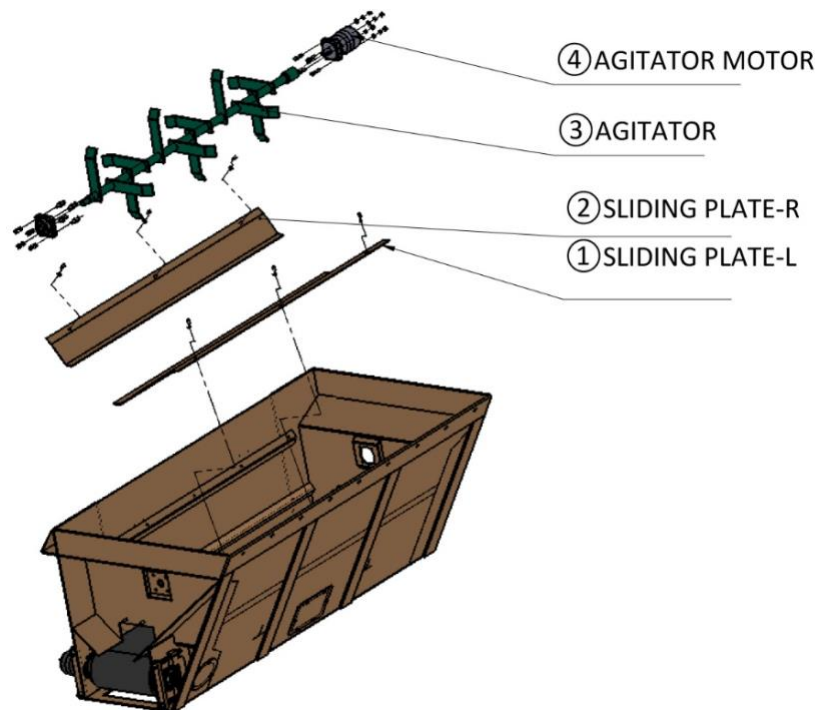

INSTRUCTIONS FOR CONVEYOR BELT REPLACEMENT

STEP 3 – PUT ON STATIONARY RACK AND CUTTING EDGE

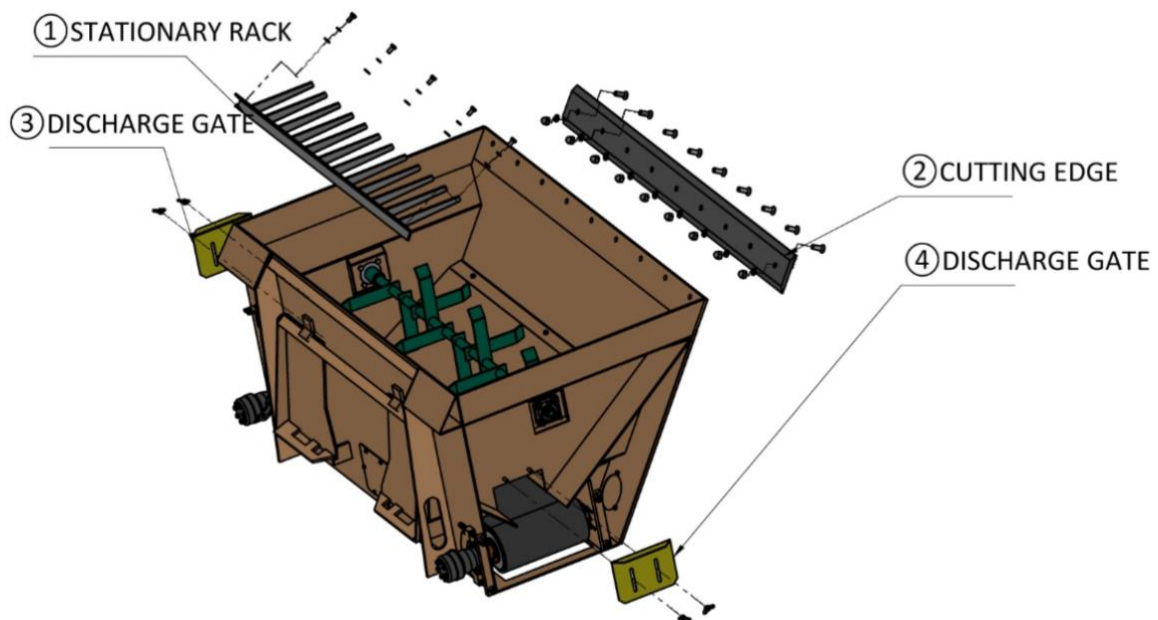

- Install the ① STATIONARY RACK on the bucket
- Install the ② CUTTING EDGE at the top of bucket
- Install the ③ DISCHARGE GATE at the left side
- Install the ④ DISCHARGE GATE at the right side

ACKNOWLEDGEMENT OF RISK AND RELEASE OF LIABILITY

The use of any equipment, including this one, involves the potential risk of injury. Apart from any warranty claim that might be presented for a claimed defect in material or workmanship of the product, you accept and assume full responsibility for any and all injuries, damages (both economic and non-economic), and losses of any type, which may occur, and you fully and forever release and discharge Titan, its insurers, employees, officers, directors, associates, and agents from any and all claims, demands, damages, rights of action, or causes of action, present or future, whether the same be known or unknown, anticipated, or unanticipated, resulting from or arising out of the use of said equipment.

This equipment must be used with care by capable and competent individuals under supervision, if necessary.

TITAN LIMITED WARRANTY: TERMS, EXCLUSIONS AND LIMITATIONS OF REMEDIES

This product comes with a one (1) year limited warranty that can be found at www.palletforks.com/warranty.html. Please review the same for all details regarding the Titan Limited Warranty.

THE TITAN LIMITED WARRANTY FOUND AT WWW.PALLETFORKS.COM/WARRANTY.HTML IS EXCLUSIVE AND IS IN LIEU OF ALL OTHER WARRANTIES, EXPRESS OR IMPLIED, INCLUDING ANY IMPLIED WARRANTY OF MERCHANTABILITY AND/OR FITNESS FOR A PARTICULAR PURPOSE, EACH OF WHICH IS HEREBY DISCLAIMED.



NEED HELP? CONTACT US FIRST.

1-800-605-7595

info@palletworks.com
www.palletforks.com

© 2021 Titan Brands