

# 72" 3 PT POWER RAKE

72PWRRAKE

191536



## Operator's Manual



Read the Operator's Manual entirely. When you see this symbol, the subsequent instructions and warnings are serious follow without exception. Your life and the lives of others depend on it!

**PARTS DIAGRAM / EXPLODED VIEW**

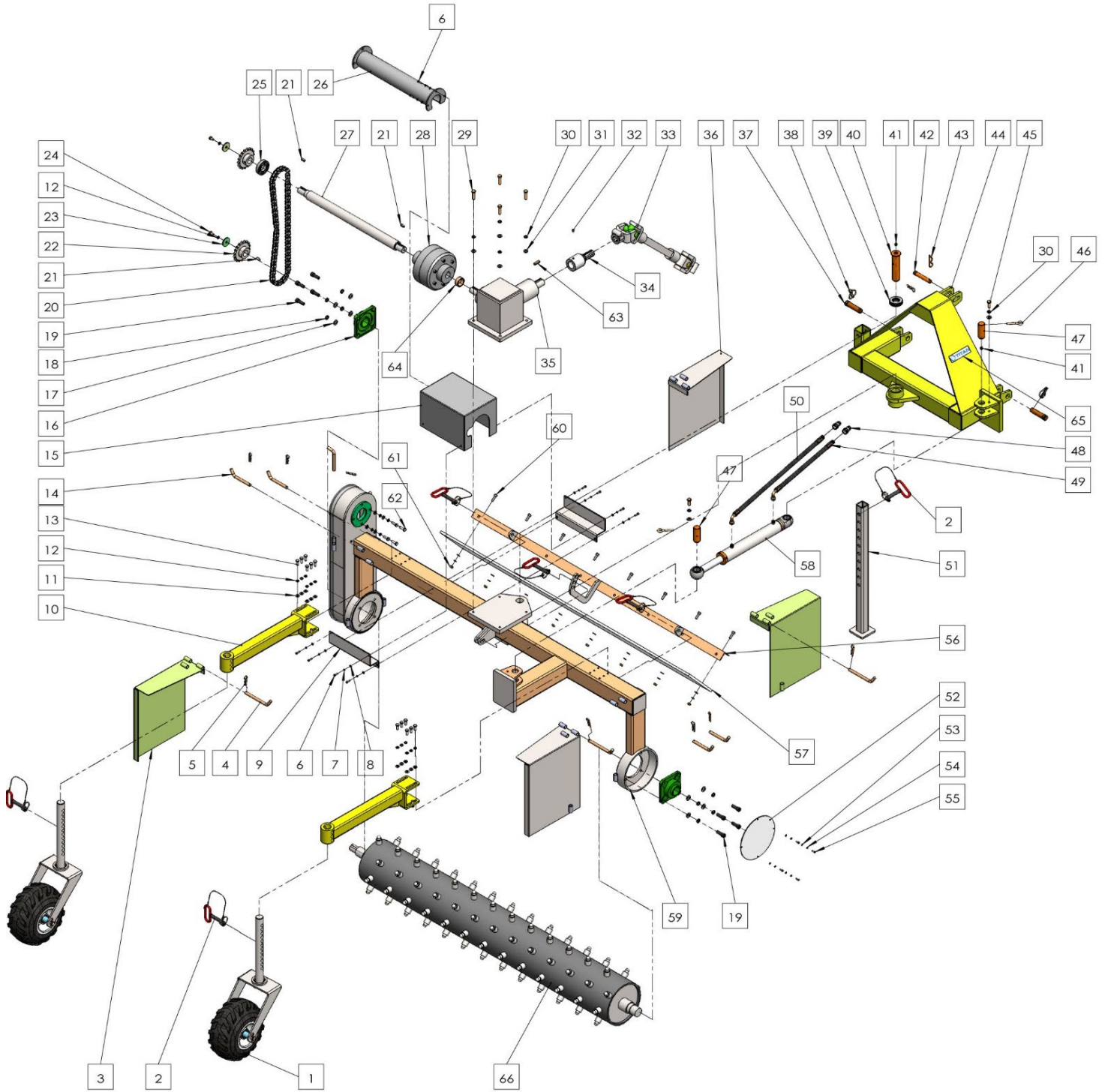

KEY	DESCRIPTION	QTY
(1)	TIRE/WHEEL ASSY	2
(2)	SAFETY PIN FOR WHEEL	2
(3)	SIDE FENDER - LEFT	2

(4)	<b>SIDE FENDER L-SHAPE PIN-1</b>	<b>4</b>
(5)	<b>COTTER PIN 4X50</b>	<b>10</b>
(6)	<b>COUNTERSUNK COLUMN HEAD HEX BOLT M6X20</b>	<b>11</b>
(7)	<b>SPRING WASHER M6</b>	<b>11</b>
(8)	<b>FLAT WASHER M6</b>	<b>11</b>
(9)	<b>SLIP CLUTCH MOUNTING BRACKET</b>	<b>2</b>
(10)	<b>WHEEL POST MOUNTING TUBE</b>	<b>2</b>
(11)	<b>FLAT WASHER M10</b>	<b>28</b>
(12)	<b>SPRING WASHER M10</b>	<b>30</b>
(13)	<b>HEX BOLT M10X25</b>	<b>12</b>
(14)	<b>SIDE FENDER L-SHAPE PIN-2</b>	<b>7</b>
(15)	<b>SLIP CLUTCH COVER</b>	<b>1</b>
(16)	<b>BALL BEARING UCFU210</b>	<b>2</b>
(17)	<b>FLAT WASHER M14</b>	<b>8</b>
(18)	<b>SPRING WASHER M14</b>	<b>8</b>
(19)	<b>COUNTERSUNK COLUMN HEAD HEX BOLT M14X40</b>	<b>8</b>
(20)	<b>DRIVE CHAIN ASSEMBLY</b>	<b>1</b>
(21)	<b>FLAT KEY 16X8X25</b>	<b>3</b>
(22)	<b>CHAIN SPROCKET</b>	<b>2</b>
(23)	<b>CHAIN SPROCKET SPACER</b>	<b>2</b>
(24)	<b>HEXA BOLT M10X16</b>	<b>2</b>
(25)	<b>BALL BEARING 6208</b>	<b>1</b>
(26)	<b>SHAFT PROTECTIVE SHIELD</b>	<b>1</b>
(27)	<b>MAIN SHAFT</b>	<b>1</b>
(28)	<b>SLIP CLUTCH ASSEMBLY</b>	<b>1</b>
(29)	<b>HEXA BOLT M12X45</b>	<b>4</b>
(30)	<b>SPRING WASHER M12</b>	<b>6</b>
(31)	<b>FLAT WASHER M12</b>	<b>6</b>
(32)	<b>COUNTERSUNK HEXA STUD BOLT M10X16</b>	<b>1</b>
(33)	<b>PTO UNIVERSAL ARM</b>	<b>1</b>
(34)	<b>PTO SPLINE SHAFT</b>	<b>1</b>
(35)	<b>90° TURN STEERING GEAR BOX</b>	<b>1</b>
(36)	<b>SIDE FENDER - RIGHT</b>	<b>2</b>

(37)	CAT1 LOWER PIN	2
(38)	LOCK PIN	2
(39)	BALL BEARING 51208	1
(40)	BEARING PIN SHAFT	1
(41)	GREASE ZERK	3
(42)	CAT1 UPPER PIN	1
(43)	COTTER PIN 4X70	1
(44)	3PT LINK FRAME	1
(45)	HEXA BOLT M12X30	2
(46)	EYE PIN	2
(47)	CYLINDER MOUNT PIN	2
(48)	PIONEER COUPLER - MALE	2
(49)	MAIN HOSE - FEED	1
(50)	MAIN HOSE - RETURN	1
(51)	LEG STAND	1
(52)	BEARING LID	1
(53)	FLAT WASHER M5	4
(54)	SPRING WASHER M5	4
(55)	COUNTERSUNK COLUMN HEAD HEXA BOLT M5X16	4
(56)	MUD DEFLECTOR MOUNTING PLATE	1
(57)	MUD DEFLECTOR	1
(58)	CYLINDER	1
(59)	SPIKE DRUM FRAME	1
(60)	COUNTERSUNK COLUMN HEAD HEXA BOLT M10X30	8
(61)	HEXA NUT M10	8
(62)	HEXA BOLT M10X30	8
(63)	FLAT KEY 12X8X40	1
(64)	SHAFT BUSHING	1
(65)	TITAN BADGE	2
(66)	SPIKE DRUM	1

## DRIVE CHAIN CASE

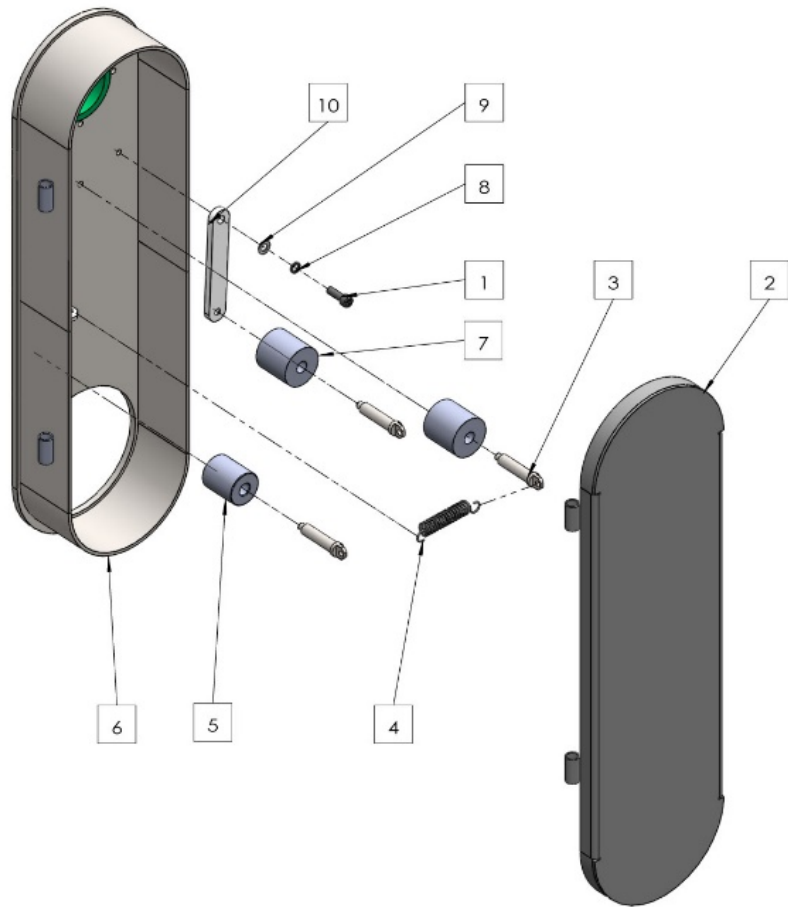

KEY	DESCRIPTION	QTY
(1)	COUNTERSUNK COLUMN HEAD HEXA BOLT M10x30	1
(2)	CASE COVER	1
(3)	PIN	3
(4)	TENSION SPRING	1
(5)	CHAIN TENSION ROLLER-1	1
(6)	DRIVE CHAIN CASE	1
(7)	CHAIN TENSION ROLLER-2	2
(8)	SPRING WASHER M10	1
(9)	FLAT WASHER M10	1
(10)	CHAIN TENSION ADJUSTMENT LEVER	1

# WHEEL/TIRE ASSEMBLY

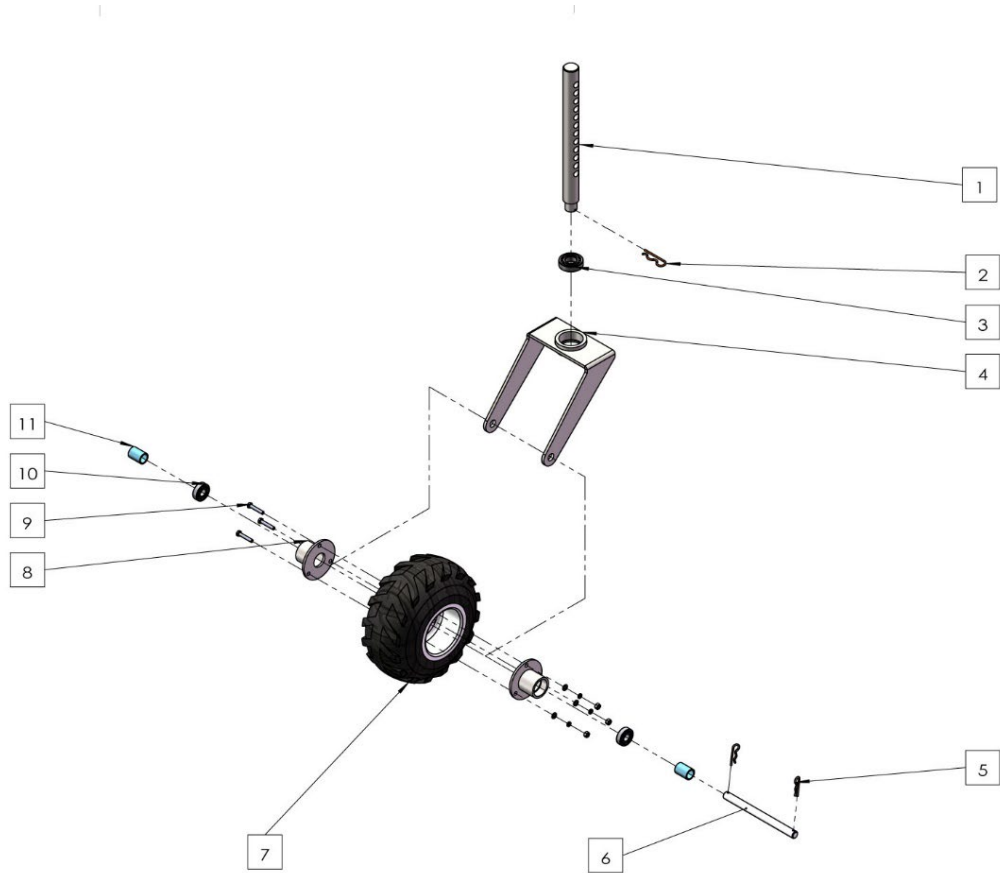

KEY	DESCRIPTION	QTY
(1)	WHEEL POST	1
(2)	COTTER PIN 4x70	1
(3)	BALL BEARING 6208	1
(4)	TIRE/WHEEL FRAME	1
(5)	COTTER PIN 4x50	2
(6)	PIN SHAFT	1
(7)	TIRE	1
(8)	BEARING ASSEMBLY	2
(9)	HEXA BOLT M8x45	3
(10)	BALL BEARING 6204	2

## ASSEMBLY INSTRUCTIONS

---

The only part that requires installation is the PTO universal arm onto the gear box as follow:

1. Insert **FLAT KEY 12x8x40 (4)** onto the slot of the shaft of **90° TURN STEERING GEAR BOX (2)**.
2. Insert **PTO SPLINE SHAFT (3)** onto **90° TURN STEERING GEAR BOX (2)** and align bolt hole.
3. Place **COUNTERSUNK HEXA STUD BOLT M10x16 (5)** into bolt hole and tighten the assembly.
4. Insert **PTO UNIVERSAL ARM (1)** onto **PTO SPLINE SHAFT (3)**.

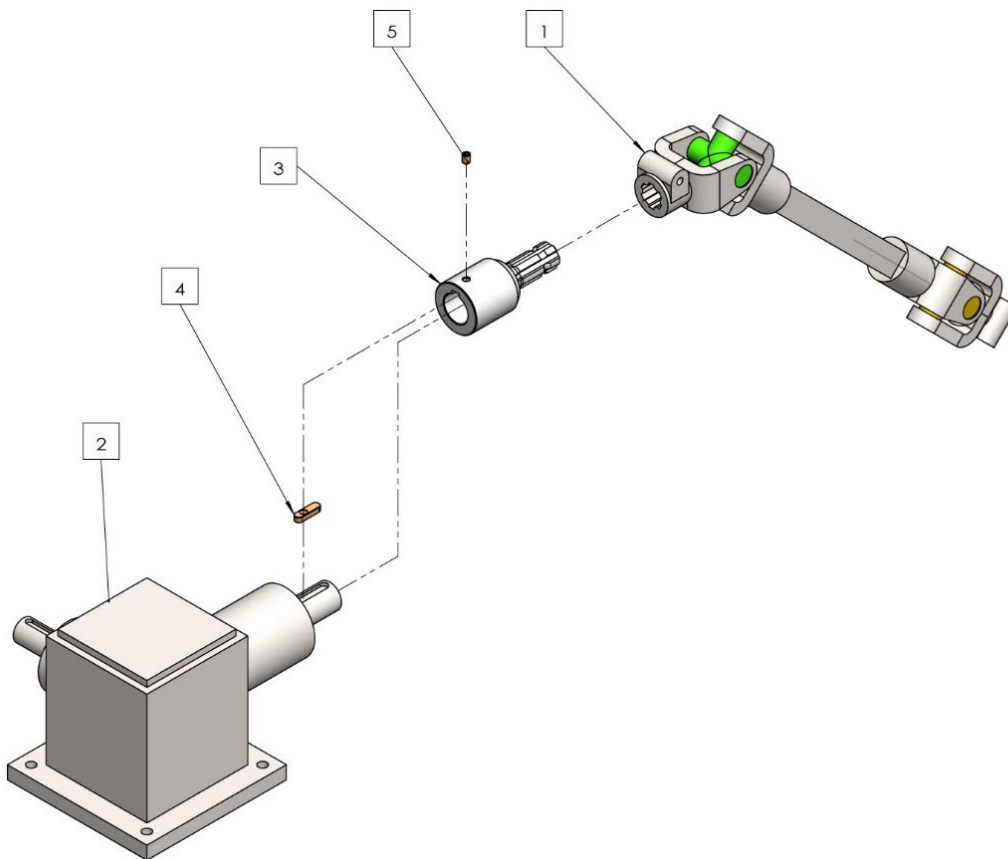

KEY	DESCRIPTION	QTY	KEY	DESCRIPTION	QTY
(1)	PTO UNIVERSAL ARM	1	(4)	FLAT KEY 12x8x40	1
(2)	90° TURN STEERING GEAR BOX	1	(5)	COUNTERSUNK HEXA STUD BOLT M10x16	1
(3)	PTO SPLINE SHAFT	1			

## ACKNOWLEDGEMENT OF RISK AND RELEASE OF LIABILITY

---

The use of any equipment, including this one, involves the potential risk of injury. Apart from any warranty claim that might be presented for a claimed defect in material or workmanship of the product, you accept and assume full responsibility for any and all injuries, damages (both economic and non-economic), and losses of any type, which may occur, and you fully and forever release and discharge Titan, its insurers, employees, officers, directors, associates, and agents from any and all claims, demands, damages, rights of action, or causes of action, present or future, whether the same be known or unknown, anticipated, or unanticipated, resulting from or arising out of the use of said equipment.

This equipment must be used with care by capable and competent individuals under supervision, if necessary.

## WARNING

---



**Do not overfill!** Mower should be level when checking oil in gear box.



some activities might be able to cause electric shock



Sharp objects may be involved.  
Use protective cover during maintenance.

## TITAN LIMITED WARRANTY: TERMS, EXCLUSIONS AND LIMITATIONS OF REMEDIES

---

This product comes with a one (1) year limited warranty that can be found at [www.palletforks.com/warranty.html](http://www.palletforks.com/warranty.html). Please review the same for all details regarding the Titan Limited Warranty.

**THE TITAN LIMITED WARRANTY FOUND AT [WWW.PALLETFORKS.COM/WARRANTY.HTML](http://WWW.PALLETFORKS.COM/WARRANTY.HTML) IS EXCLUSIVE AND IS IN LIEU OF ALL OTHER WARRANTIES, EXPRESS OR IMPLIED, INCLUDING ANY IMPLIED WARRANTY OF MERCHANTABILITY AND/OR FITNESS FOR A PARTICULAR PURPOSE, EACH OF WHICH IS HEREBY DISCLAIMED.**





**NEED HELP? CONTACT US FIRST.**

**1-800-605-7595**

[info@palletworks.com](mailto:info@palletworks.com)  
[www.palletforks.com](http://www.palletforks.com)

© 2021 Titan Brands