

# 3PT PTO STUMP GRINDER

---

PTO24STMPGRNDR

191382



## Operator's Manual



Read the Operator's Manual entirely. When you see this symbol, the subsequent instructions and warnings are serious follow without exception. Your life and the lives of others depend on it!



## IMPORTANT SAFETY INFORMATION

---

### **IMPORTANT NOTE: MUST ADD OIL TO GEARBOX BEFORE FIRST USE!**

**THESE ARE COMMON PRACTICES THAT MAY OR MAY NOT BE APPLICABLE TO THE PRODUCTS DESCRIBED IN THIS MANUAL.**

#### **DANGER!**

DANGER - Indicates a hazardous situation, which, if not avoided, WILL result in death or serious injury.

#### **WARNING!**

WARNING - Indicates a hazardous situation, which, if not avoided, could result in death or serious injury.

#### **CAUTION!**

CAUTION - Indicates a hazardous situation, which, if not avoided, could result in minor or moderate injury.

#### **NOTICE**

NOTICE - Indicates a situation that could result in damage to the equipment or other property.

#### **DO NOT ALLOW RIDERS**

NEVER lift or carry anyone on stump grinder.

NEVER use stump grinder as a work platform.

NEVER allow passengers on stump grinder.

#### **WARNING!**

Prevent serious injury or death.

Read and understand this manual before operating stump grinder.

Always stop engine and remove key before leaving operator's seat.

Never allow anyone near the stump grinder during operation.

Prevent serious injury or death from moving parts.

Moving parts can crush and dismember. Do not operate without guards and shields in place.

Disconnect and lockout power source before adjusting or performing maintenance.

Use stump grinder only for the designed applications.

Any other use may result in personal injury, damage to equipment and may void the warranty.

Verify stump grinder is locked to quick attach hitch before operation or transport.

#### **AVOID ROLLOVER**

The equipment may rollover, resulting in death or serious injury. To help prevent rollover:

- Travel at a slow speed.
- Avoid sharp turns & sudden movement on slopes.
- Carry stump grinder close to the ground.
- Avoid holes, ditches and other obstructions which may cause equipment to rollover.
- Use caution when operating on slopes and do not operate on excessively steep slopes.
- Do not exceed load capacity of equipment.

## IMPORTANT SAFETY INFORMATION

---

### THESE ARE COMMON PRACTICES THAT MAY OR MAY NOT BE APPLICABLE TO THE PRODUCTS DESCRIBED IN THIS MANUAL.

#### AVOID POWER LINES & UNDERGROUND UTILITIES

##### **DANGER!**

Prevent electrocution.

Death or serious injury can result if equipment comes near or contacts power lines.

Electrocution can occur without direct contact.

Check clearance before raising equipment.

Have local utilities locate and mark underground wires, cables, pipelines, and other hazards before digging.

DO NOT leave the operator's seat if any part of the equipment contacts electric lines or cables.

#### RAISED ATTACHMENT

##### **WARNING!**

Crushing hazard.

Raised, unsupported stump grinder can fall, resulting in death or serious injury.

Never enter the area under a raised stump grinder.

A raised stump grinder can lower unexpectedly, resulting in death or serious injury.

NEVER enter area under a raised stump grinder.

Lower stump grinder to ground, engage parking brake, shut off engine and remove key before servicing.

#### AVOID HIGH PRESSURE FLUIDS

##### **WARNING!**

Pressurized fluids can penetrate the skin.

Hydraulic hoses can fail from age, damage, and exposure.

Use body and face protection while searching for leaks. A tiny, almost invisible leak can penetrate the skin, thereby requiring immediate medical attention.

Use wood or cardboard to detect hydraulic leaks, never use your hands.

Escaping fluid under pressure can penetrate the skin causing serious injury.

Prevent the hazard by relieving pressure before connecting or disconnecting hydraulic lines. Verify all connections are tight before applying pressure. Search for leaks with a piece of cardboard or wood.

Protect hands and body from high pressure fluids. If an accident occurs, see a doctor immediately.

#### DETACH STUMP GRINDER SAFELY

Detach stump grinder on a firm and level surface. Stump grinder may fall over if detached on unlevel or soft surface.

##### **TRANSPORT SAFELY**

Carry stump grinder low. Travel slow and avoid slopes.

##### **LOWER OPERATING SPEED**

Keep stump grinder low and move at slow speeds on rough or uneven terrain.

## INSTRUCTIONS

---

### TRACTOR REQUIREMENTS AND PREPARATION.

The models **PTO24STMPGRNDR** PTO driven stump grinders are designed to mount on tractors that have a 3pt. hitch and a 540 rpm PTO (power take off) in good working condition.

The model **PTO24STMPGRNDR** requires a tractor of at least 20 hp or up to a maximum of 60 hp and a Category QH1 and QH2 hitch.

It is recommended that only tractors with wide front axles be used with these stump grinders. Tricycle front wheel arrangements are inherently unstable and tractor roll-over accidents are more likely to occur.

The tractor also needs lift arm stabilizer bars or sway blocks to control side movement of the stump grinder. Check the tractor's 3 pt. hydraulic lift system. Refer to your tractor operator's manual or dealer for any adjustments necessary to put the hydraulic system in good working order.

Tractor must be equipped with two (2) independent pair of remote hydraulic outlets to operate these stump grinders.

Be sure tires and rims are in good condition. Inflate tires to the proper recommended air pressure. Check the tractor master shield over the PTO stub shaft.

Make sure it is in good condition and fastened securely to the tractor. Purchase a new shield if old shield is damaged or missing.

It is recommended that a ROPS (Roll-Over Protection Structure) and a seat belt be installed on all tractors. Keep foldable ROPS systems in "locked up" position at all times. Contact your local dealer for a ROPS for your tractor.

Most swinging drawbars will have to be moved to a forward position or removed. Check the tractor swinging drawbar for interference with the front of the stump grinder. The swinging drawbar can be moved forward on some tractors, or it can be removed.

#### **RAISED ATTACHMENT WARNING!**

When using the unit, a minimum 20% of tractor and equipment weight must be on tractor front wheels.

Without this weight, tractor could tip up, causing possible loss of control and possible personal injury or death. The weight may be attained with a front-end loader, front wheel weights, ballast in tires or front tractor weights. When attaining a minimum 20% of tractor and equipment weight on the front wheels, you must not exceed the ROPS weight certification. Weigh the tractor and equipment.

#### **DO NOT GUESS OR ESTIMATE!**

#### **CAUTION!**

**Be sure your tractor is in good condition. Read all the safety precautions and make sure all tractor operators are familiar with the safety rules of operation.**

#### **WARNING!**

**A heavy load can cause instability in driving a tractor. Make sure the front of the tractor is properly counterbalanced with weights. Always drive slowly especially around turns. An unstable tractor could steer badly and possibly tip over, causing injury or death.**

## INSTRUCTIONS

### TRACTOR 3 PT. ASSEMBLY AND MOUNTING

This unit is shipped almost completely assembled. Carefully follow instructions for final assembly. Before attempting assembly check the following items. Having all the needed parts and equipment readily at hand will speed up your assembly task and will make the job as safe as possible.

Refer to the repair parts drawing in this manual to get an idea of how the parts need to be assembled for each individual implement model.

Check for fasteners and pins that were shipped with the stump grinder. All hardware coming from the factory has been installed in the location where it will be used. If a part or fastener is temporarily removed for assembly reasons, remember where it goes. Keep the parts separated.

Have a fork lift or loader along with chains and safety stands that are sized for the job ready for the assembly task.

Never let anyone stand between the rear of the tractor and the stump grinder while the tractor is backing up. Always stand to the side until tractor has come to a complete stop and the brakes set or the tractor shift placed in "PARK."

1. Back tractor to align lift arms with stump grinder hitch points.
2. Attach both lower lift arms to stump grinder. Secure with lynch pins. Tractor lift arm stabilizer bars or sway blocks must be used to control side movement of the stump grinder. **DO NOT CONNECT THE PTO DRIVELINE AT THIS TIME.**
3. Install suitable top link between tractor and stump grinder. Secure with link pins and lynch pins.
4. Lift stump grinder and check to see that both 3 pt. lift arms are the same height. Adjust using crank if necessary to level the implement from side to side.

#### REPLACE CUTTING TEETH

1. Support stump grinder to prevent falling.
2. Stop skid steer engine and remove key.
3. Inspect cutting teeth for damage. Rotated the tooth 3 times before replace it.

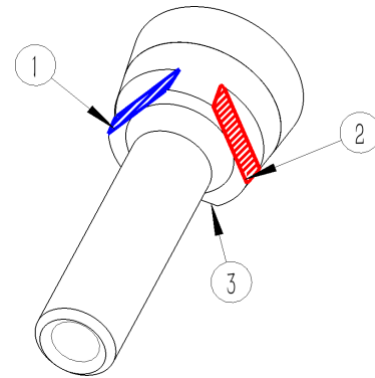

4. Replace individual teeth as needed.
5. Remove lock nut (1) and cutting tooth (2)

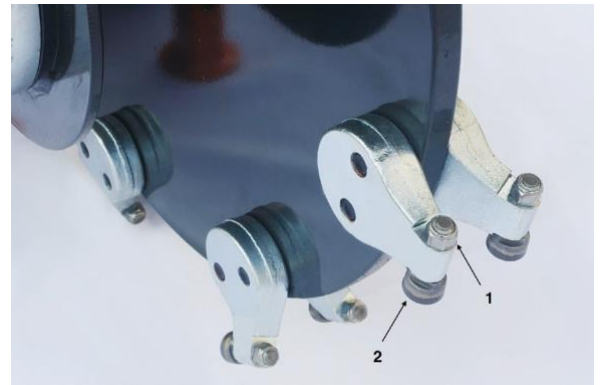

6. Rotated the tooth or install replacement tooth and lock nut. Tighten locknut (1) to 95 lb./ft. (129 Nm) of torque. Do not allow untrained or unqualified people to operate this equipment.

## INSTRUCTIONS

### HOW TO CUT STUMPS

When engaging and disengaging the PTO, the engine speed should always be low. Once the PTO is engaged and ready to start cutting, raise the PTO speed to 540 RPM and maintain throughout stump cutting operation.

ALWAYS operate the PTO at 540 RPM. This is necessary to maintain proper wheel speed to obtain a clean, smooth cut. Do not disengage PTO when the engine is at full PTO RPM. Always bring the tractor engine to idle speed before disengaging the PTO.

When the first cutting pass is complete, raise the cutting wheel slightly with the depth control cylinder (or skid steer bucket tilt cylinders) and then activate the side control cylinder to move the wheel back to the start position.

Lower the cutter wheel and make a deeper cut. Repeat the previous steps until you have cut approximately 12 inches (30 cm) of the stump.

Operate the cutting wheel at 540 rpm (speed while under no load).

The cutting wheel feed is controlled by the hydraulic cylinder and the pressure control valve.

The rate of cut will depend on the type of tree, condition of the wood, and the condition of the carbide cutting teeth.

Excessive feed rates will either stall the engine or slip the clutch.

Too light a feed will produce sawdust.

#### Above Ground (Large Stump)

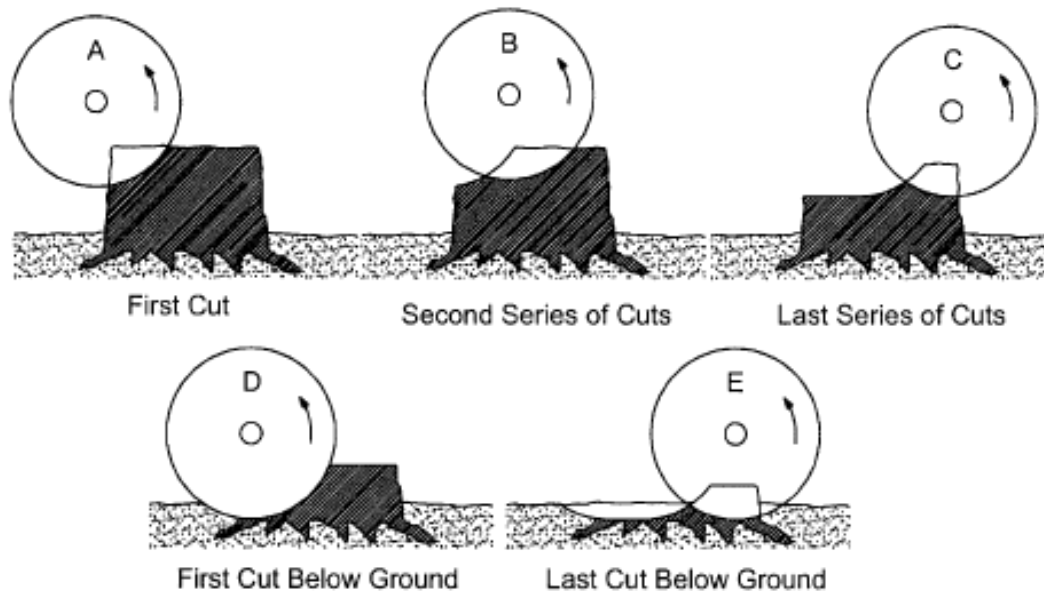

#### Below Ground

**PARTS DIAGRAM / EXPLODED VIEW**

DESCRIPTION	SPECIFICATION
MAXIMUM CUTTING DEPTH - BELOW GROUND	12"
MAXIMUM CUTTING HEIGHT - ABOVE GROUND	18"
CUTTING ARC (DEGREES)	40°
TYPE OF PTO INCLUDED	20-60HP
REQUIRED HYDRAULIC FLOW	5-13GPM
CUTTING WHEEL SPEED	950 U/MIN
MAX OUTPUT TORQUE	200NM
NUMBER OF CUTTING TEETH	16
CATEGORY	QH1 AND QH2
WEIGHT	620 LB

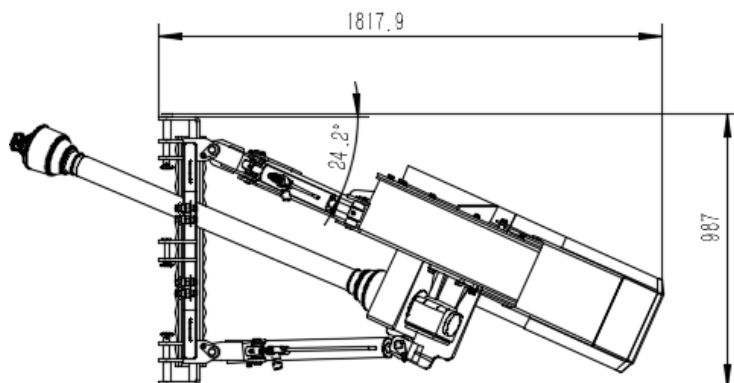
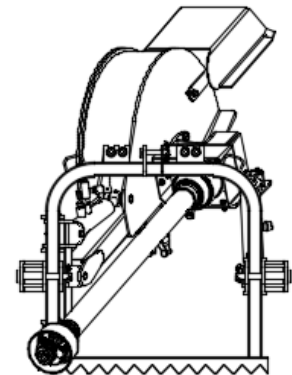
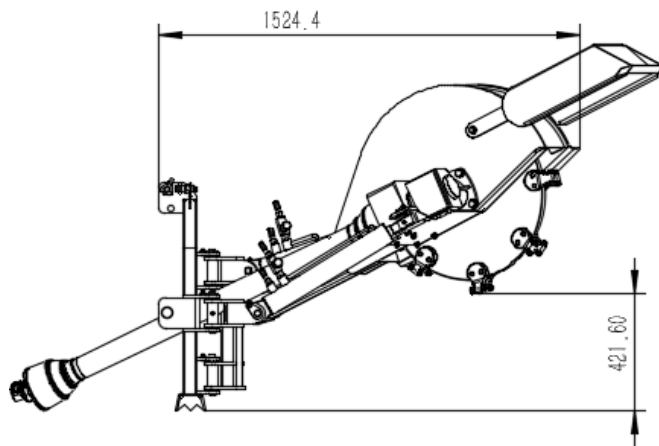

# PARTS DIAGRAM / EXPLODED VIEW

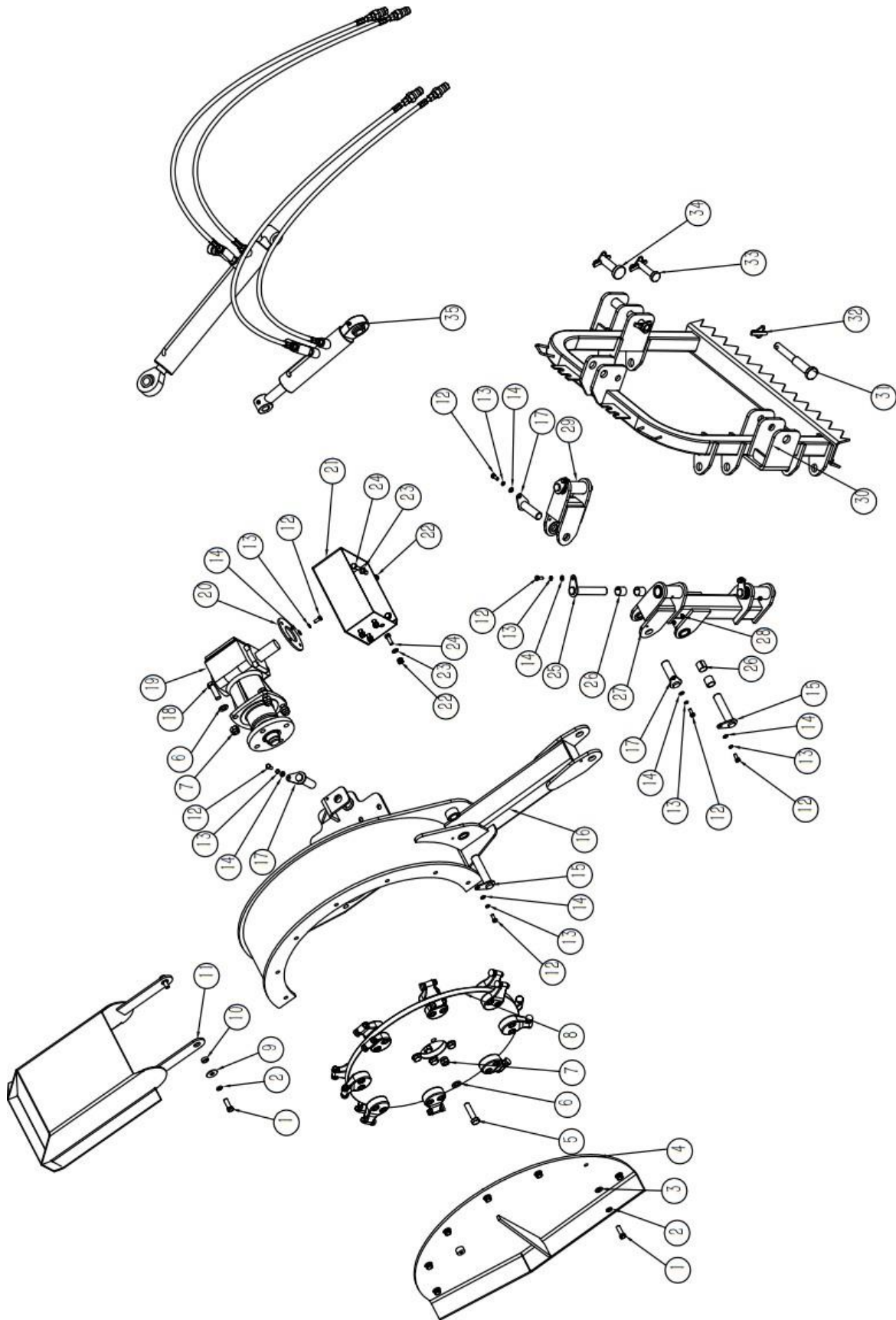



KEY	BOX	DESCRIPTION	QTY
1	GB/T 5783	BOLT M12X35	9
2	GB/T93.1	SPRING WASHER 12	9
3	GB/T 97.1	WASHER 12	7
4	TSG61.7	OUTER PLATE WELDMENT	1
5	GB/T 5783	BOLT M16*65	4
6	GB/T 97.1	WASHER 16	8
7	GB/T 889.1	LOCK NUT M16	8
8	SSG61.4	CUTTING WHEEL ASSEMBLY	1
9	GB/T 96-1985	BIG WASHER 12	2
10	TSG61.15	GUARD SPACER	2
11	TSG61.6	GUARD WELDMENT	1
12	GB/T 5783	BOLT M8X20	12
13	GB/T93.1	SPRING WASHER 8	12
14	GB/T 97.1	WASHER 8	12
15	TSG61.9	CYLINDER PIN 1	2
16	TSG61.1	FRAME WELDMENT	1
17	TSG61.10	CYLINDER PIN 2	3
18	GB/T 5783	BOLT M16X50	4
19	TSG61.8	GEARBOX ASSEMBLY	1
20	TSG61.13	GEARBOX PROTECTION PLATE	1
21	TSG61.5	GEARBOX PROTECTION COVER	1
22	GB/T 889.1	LOCK NUT M10	8
23	GB/T 97.1	WASHER 10	8
24	GB/T 5783	BOLT M10X30	8
25	TSG61.11	ROTARY LINKAGE WELDMENT	3
26	TSG61.30	BEARING 28X25X25	8
27	TSG61.2	ROTARY WELDMENT	1
28	JB / T 7940.1-1995	GREASE NIPPLE M8	4
29	TSG61.3	ROTARY WELDMENT 2	1
30	TSG61.4A	SUPPORTING WELDMENT	1
31	TLL5.2	LOWER PIN	2
32	TSG61.31	LOCK PIN 10*45	4
33	TLL5.5	UPPER PIN 01	1
34	TLL5.6	UPPER PIN 02	1
35	TSG61.12	HYDRAULIC COMPONENTS	1

HYDRAULIC COMPONENT PARTS DIAGRAM / EXPLODED VIEW

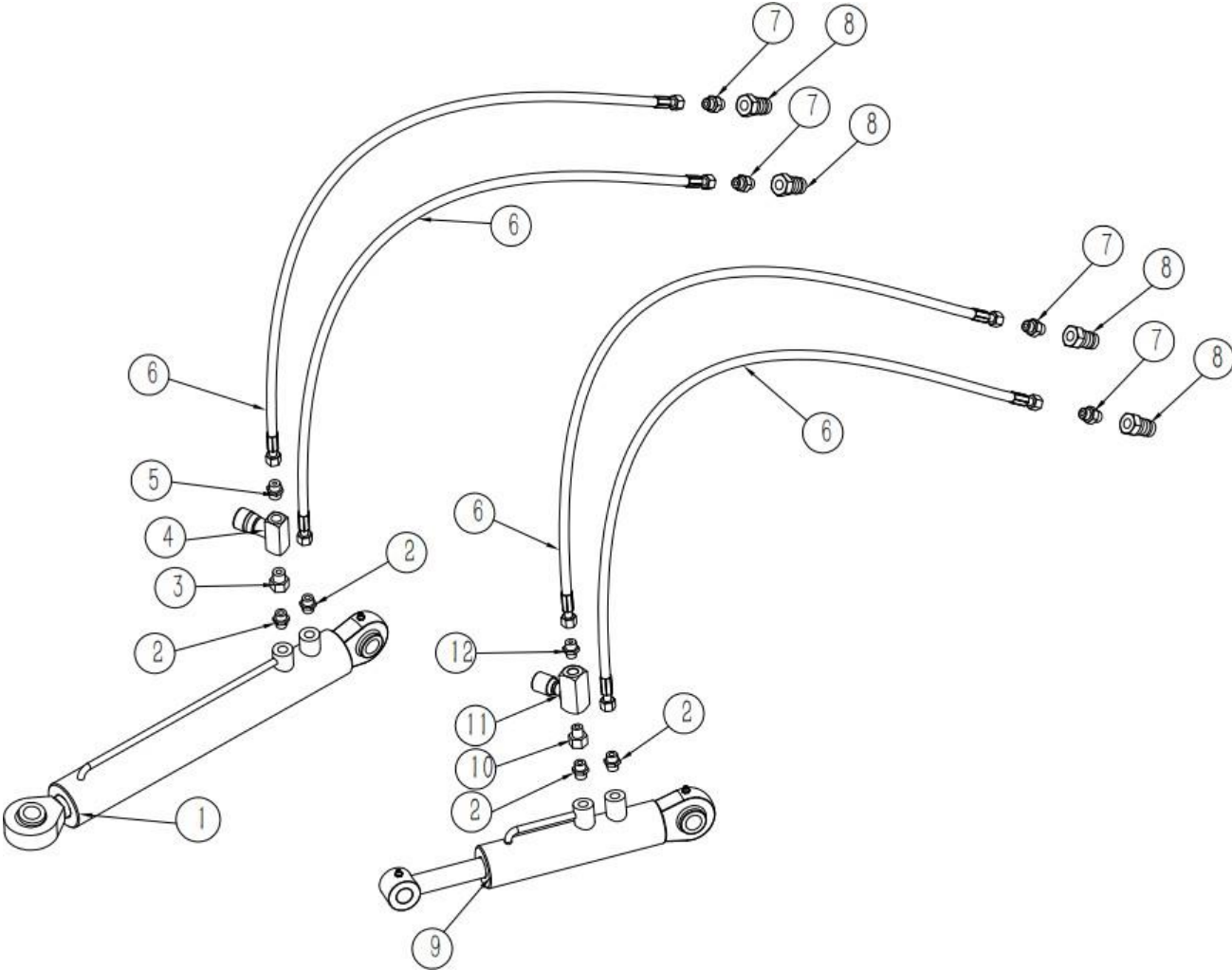

ASSEMBLY INSTRUCTIONS

---

KEY	BOX	DESCRIPTION	QTY
35-1	TSG61.12-2	SWING CYLINDER	1
35-2	GE10LM16X1.5EDOMD	END STRAIGHT JOINT M16X1.5-M16X1.5	4
35-3	EGE10LR38ED	END STRAIGHT JOINT M16X1.5-G3/8	1
35-4	STB 3/8	CONTROL VALVE	1
35-5	GE10LR38EDOMD	END STRAIGHT JOINTM16X1.5-G3/8	1
35-6	TSG61.12-3	OIL HOSE	4
35-7	GE10LR1/2ED	END STRAIGHT JOINT M16*1.5-G1/2"	4
35-8	GB/T 5862	QUICK CHANGE CONNECTOR G1/2	4
35-9	TSG61.12-1	LIFTING CYLINDER	1
35-10	EGE10LRED	END STRAIGHT JOINT M16X1.5-G1/4	1
35-11	STU 1/4	ONE-WAY FLOW CONTROL VALVE	1
35-12	GE10LR14ED	END STRAIGHT JOINT M16X1.5-G1/4	1

## CUTTING WHEEL PARTS DIAGRAM / EXPLODED VIEW

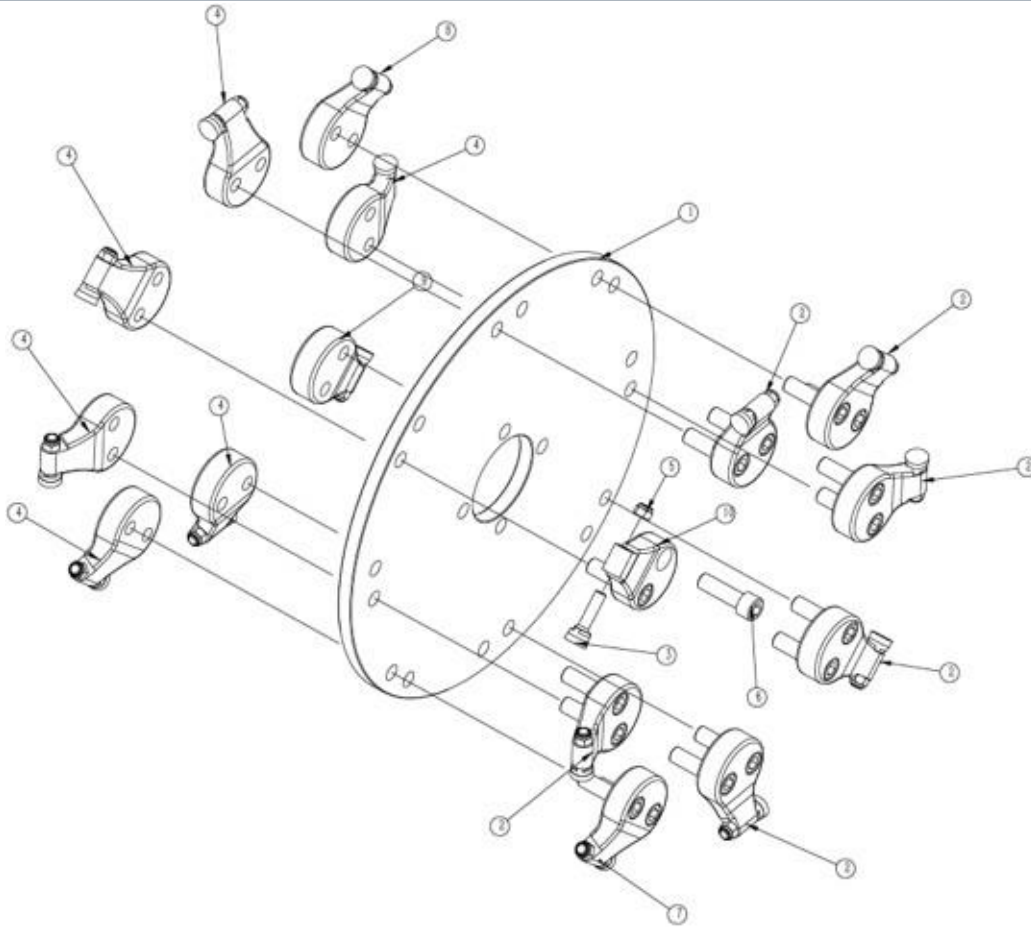

KEY	BOX	DESCRIPTION	QTY
1	SSG61.4-7	CUTTING WHEEL	1
2	ESG47.4-2	TEETH BASE900-2	6
3	ESG47.4-8	TEETH 900	16
4	ESG47.4-3	TEETH BASE900-3	6
5	ASME B18.16.6	NYLON INSERT LOCK NUTS	16
6	ASME B18.3	HEX SOCKET HEAD BOLT	16
7	ESG47.4-4	TEETH BASE900-4	1
8-8	ESG47.4-5	TEETH BASE900-5	1
8-9	ESG47.4-6	TEETH BASE900-6	1
8-10	ESG47.4-1	TEETH BASE900-1	1

## ACKNOWLEDGEMENT OF RISK AND RELEASE OF LIABILITY

---

The use of any equipment, including this one, involves the potential risk of injury. Apart from any warranty claim that might be presented for a claimed defect in material or workmanship of the product, you accept and assume full responsibility for any and all injuries, damages (both economic and non-economic), and losses of any type, which may occur, and you fully and forever release and discharge Titan, its insurers, employees, officers, directors, associates, and agents from any and all claims, demands, damages, rights of action, or causes of action, present or future, whether the same be known or unknown, anticipated, or unanticipated, resulting from or arising out of the use of said equipment.

This equipment must be used with care by capable and competent individuals under supervision, if necessary.

## WARNING

---



**Do not overfill!** Mower should be level when checking oil in gear box.



some activities might be able to cause electric shock



Sharp objects may be involved.  
Use protective cover during maintenance.

## TITAN LIMITED WARRANTY: TERMS, EXCLUSIONS AND LIMITATIONS OF REMEDIES

---

This product comes with a one (1) year limited warranty that can be found at [www.palletforks.com/warranty.html](http://www.palletforks.com/warranty.html). Please review the same for all details regarding the Titan Limited Warranty.

**THE TITAN LIMITED WARRANTY FOUND AT [WWW.PALLETFORKS.COM/WARRANTY.HTML](http://WWW.PALLETFORKS.COM/WARRANTY.HTML) IS EXCLUSIVE AND IS IN LIEU OF ALL OTHER WARRANTIES, EXPRESS OR IMPLIED, INCLUDING ANY IMPLIED WARRANTY OF MERCHANTABILITY AND/OR FITNESS FOR A PARTICULAR PURPOSE, EACH OF WHICH IS HEREBY DISCLAIMED.**



**NEED HELP? CONTACT US FIRST.**

**1-800-605-7595**

[info@palletworks.com](mailto:info@palletworks.com)

[www.palletforks.com](http://www.palletforks.com)

© 2023 Titan Brands