

X3 SERIES FOLDING POWER RACK

X3FLDUP82 - X3FLDSB21, X3FLDUP82 - X3FLDSB41,
X3FLDUP91 - X3FLDSB21, X3FLDUP91 - X3FLDSB41
401394, 401396, 401393, 401395



Operator's Manual



Read the Operator's Manual entirely. When you see this symbol, the subsequent instructions and warnings are serious follow without exception. Your life and the lives of others depend on it!

FULL ASSEMBLY/EXPLODED VIEW/ FULL PARTS LIST

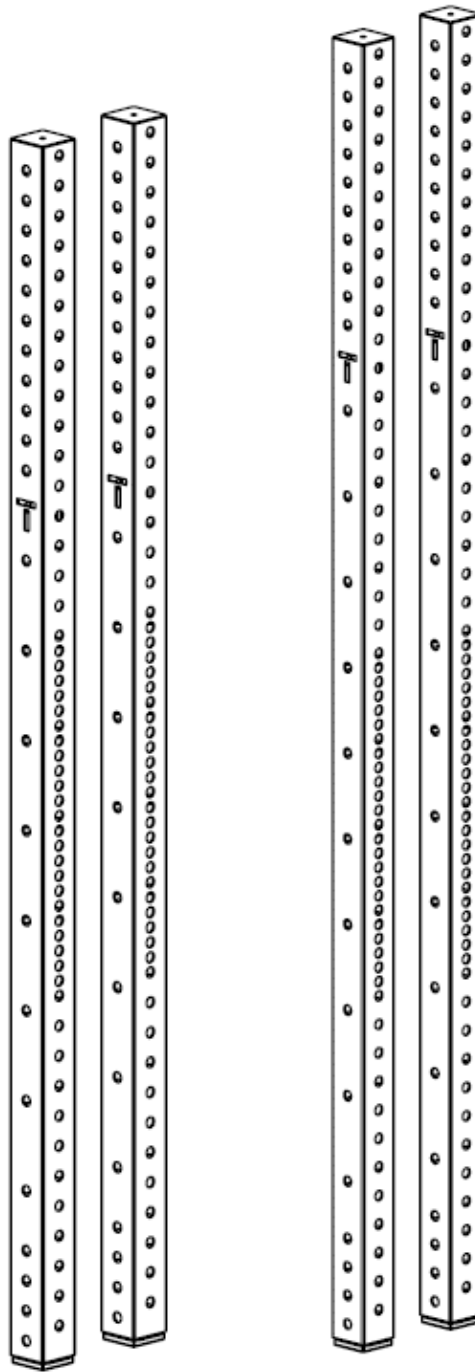

AVAILABLE IN 82" OR 91" UPRIGHTS

KEY	BOX	DESCRIPTION	QTY
(1)	1	82" X3 FOLDING UPRIGHT FRAME	2
(2)	1	91" X3 FOLDING UPRIGHT FRAME	2

21" FOLDING ARMS - FULL ASSEMBLY/EXPLODED VIEW/ FULL PARTS LIST

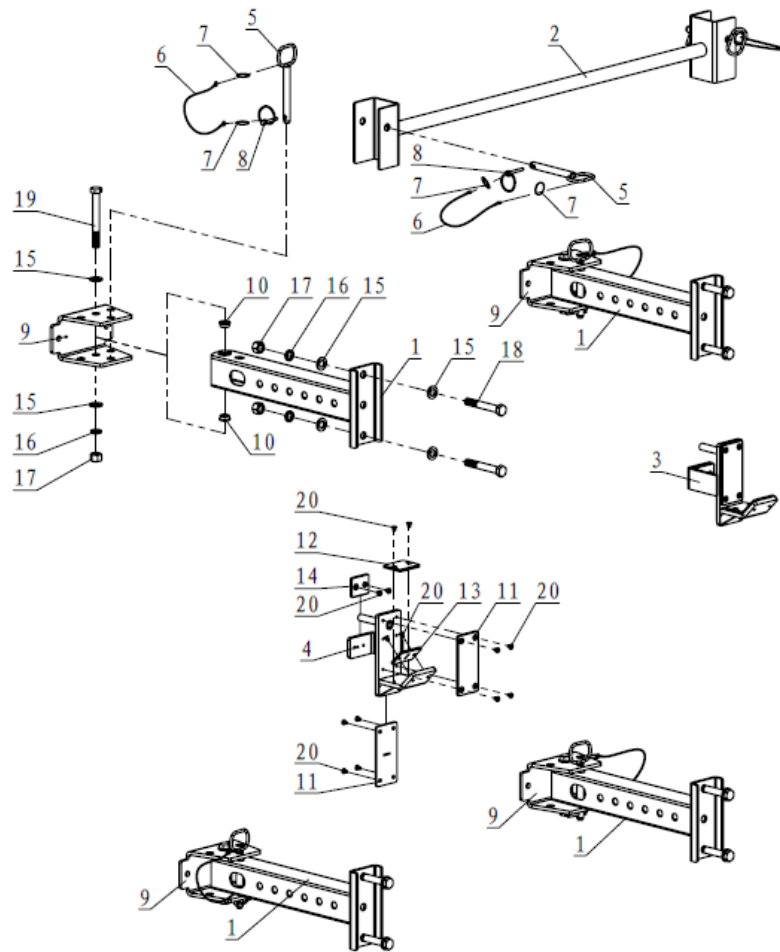

KEY	BOX	DESCRIPTION	QTY	KEY	BOX	DESCRIPTION	QTY
(1)	1	Rear Connecting Frame	4	(11)	1	Long Plastic Plate 148*68*5	4
(2)	1	Pull Up Bar	1	(12)	1	Plastic Plate 68*58*5	2
(3)	1	J-Hook(L)	1	(13)	1	Front Plastic Plate 68*48*5	2
(4)	1	J-Hook(R)	1	(14)	1	Short Plastic Plate 58*48*5	2
(5)	1	Hitch Pin $\Phi 16*140$	6	(15)	1	Flat Washer $\Phi 17*\Phi 30*3$	24
(6)	1	Cable $\Phi 5.5*\Phi 1.6*330$	6	(16)	1	Spring Washer $\Phi 16$	12
(7)	1	Pull Ring $\Phi 6*182$	12	(17)	1	Nut M16	12
(8)	1	Small Pin $\Phi 6*45$	6	(18)	1	Hex Bolt M16*110	8
(9)	1	Retaining Bracket	4	(19)	1	Hex Bolt M16*135	4
(10)	1	$\Phi 16$ Bushing	8	(20)	1	Countersunk head screw M6*10	28

ASSEMBLY INSTRUCTIONS

Step 1

1. Connect the Rear Connecting Frame (1) and Upright Frame (21), using Flat Washer $\Phi 17*\Phi 30*3$ (15), Spring Washer $\Phi 16$ (16), M16 Nut (17) and Hex Bolt M16*110(18).
2. Connect the Retaining Bracket (9) to Rear Connecting Frame (1), using Hitch Pin (5).

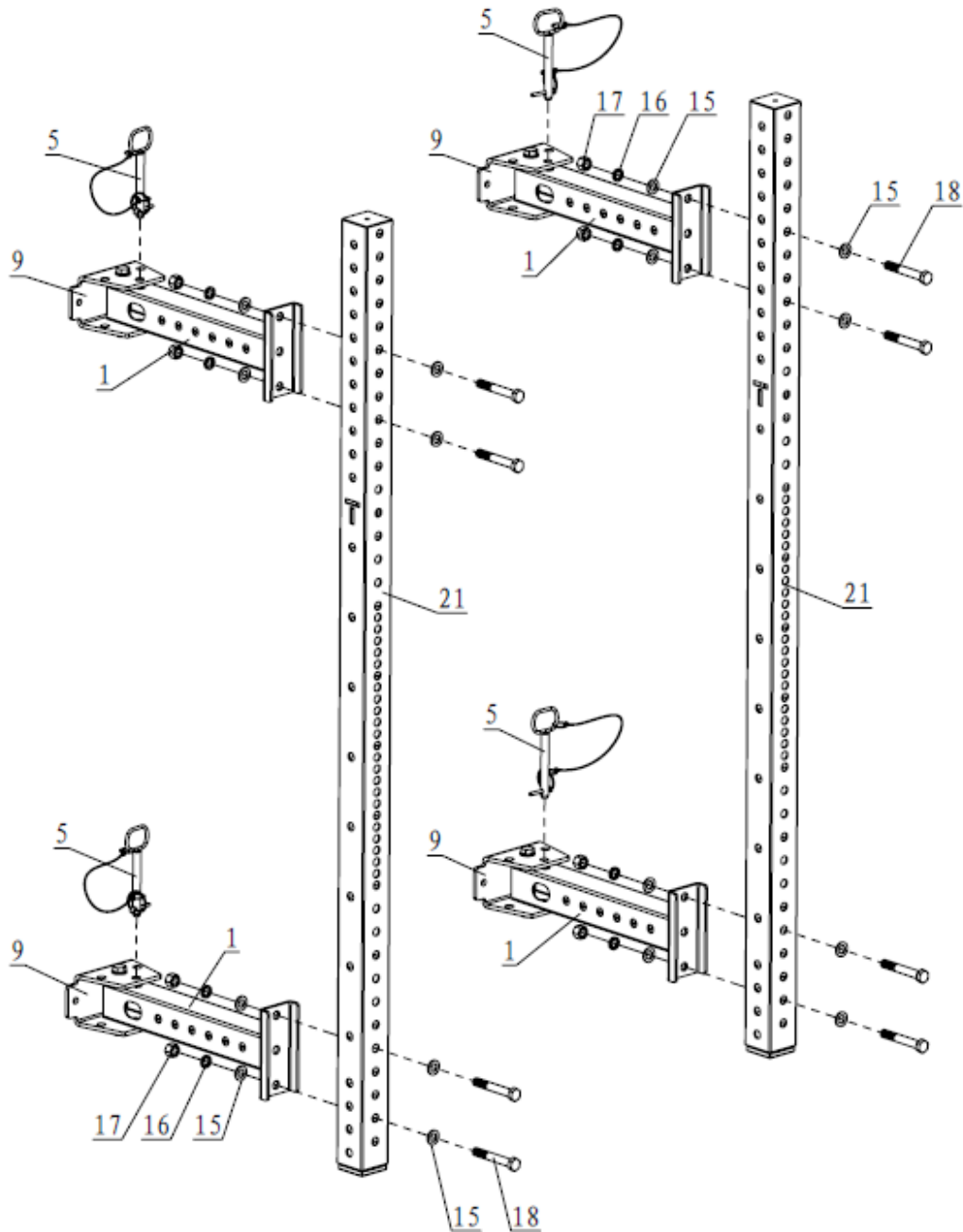

Step 2

1. Fixing the Pull Up Bar (2) on the Upright Frame (21), using the Hitch Pin (5).
2. Fixing the Retaining Bracket (4) on the Wall.
3. Install the Left and Right J-Hook (3&4) on the Upright Frame (21).

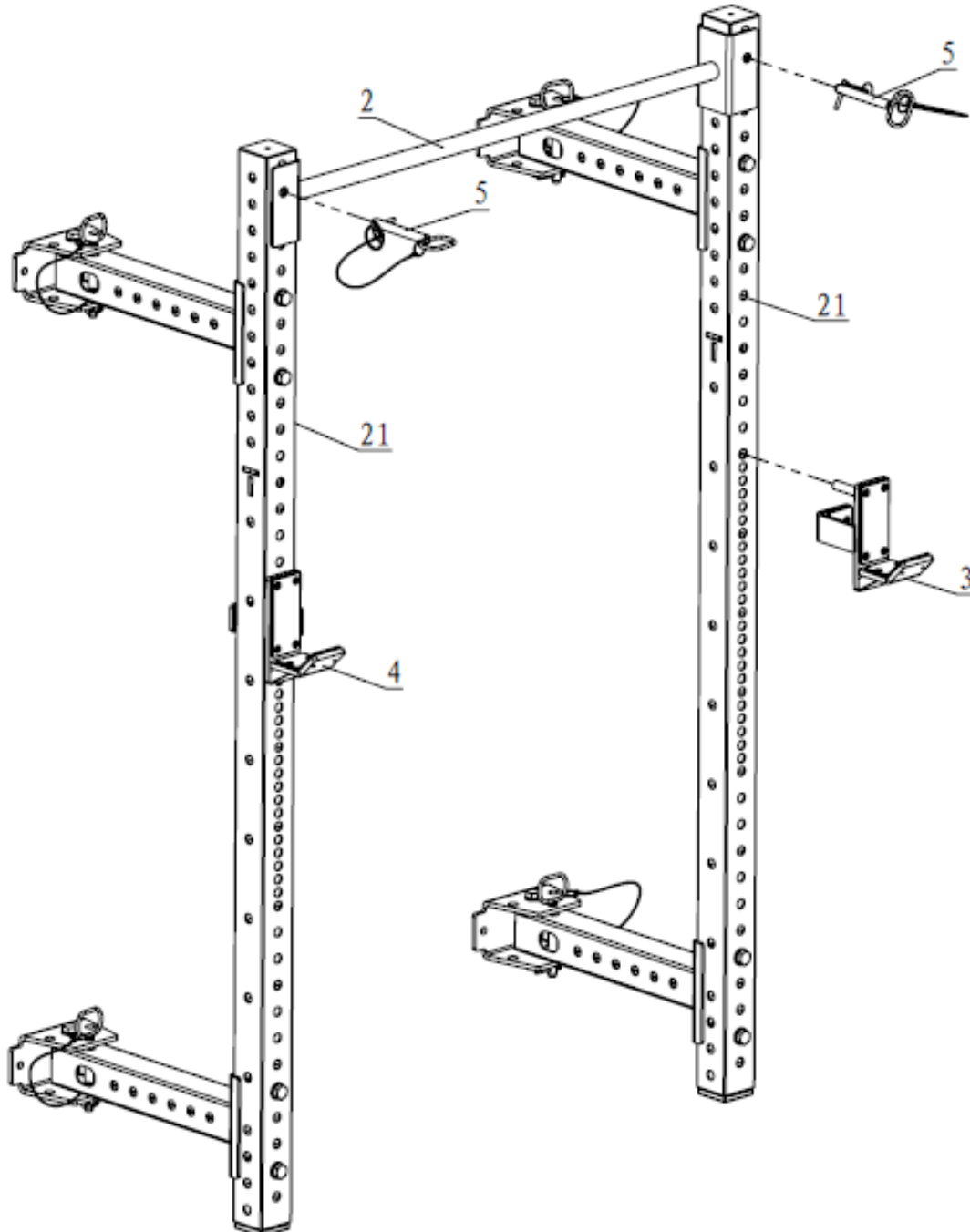

41" FOLDING ARMS - FULL ASSEMBLY/EXPLODED VIEW/ FULL PARTS LIST

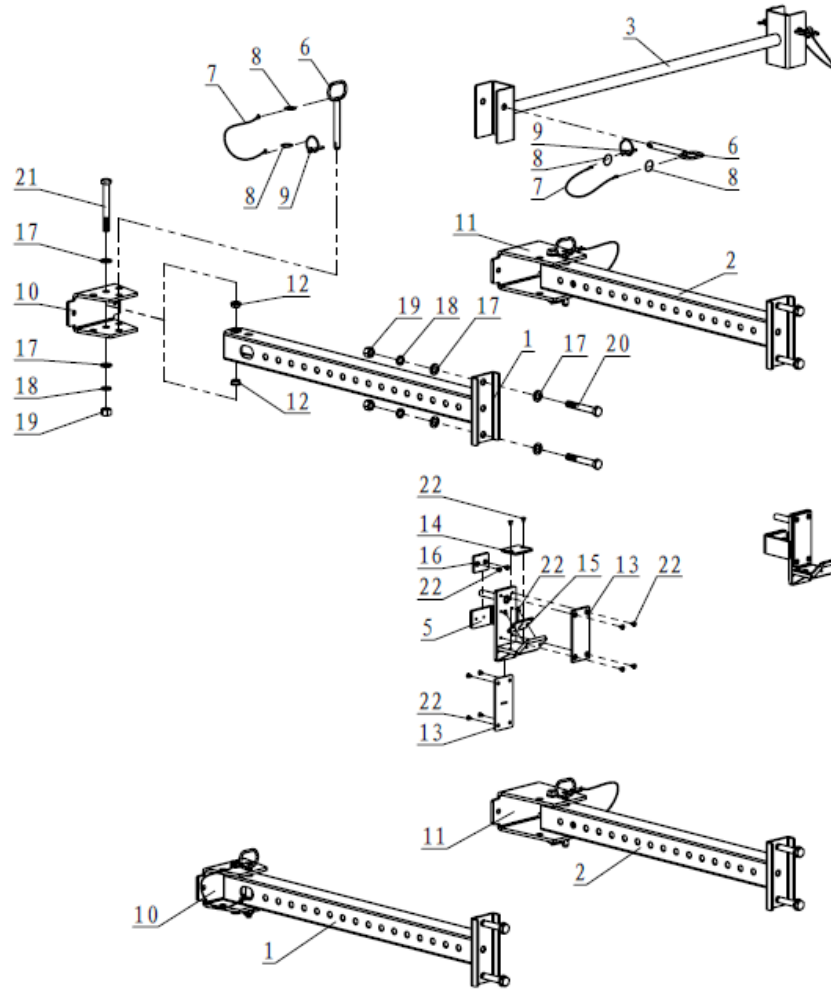

KEY	BOX	DESCRIPTION	QTY	KEY	BOX	DESCRIPTION	QTY
(1)	1	Rear Connecting Frame	2	(12)	1	Φ16 Bushing	8
(2)	1	Rear Short Connecting	2	(13)	1	Long Plastic Plate 148*68*5	4
(3)	1	Pull Up Bar	1	(14)	1	Plastic Plate 68*58*5	2
(4)	1	J-Hook(L)	1	(15)	1	Front Plastic Plate 68*48*5	2
(5)	1	J-Hook(R)	1	(16)	1	Short Plastic Plate 58*48*5	2
(6)	1	Hitch Pin Φ16*140	6	(17)	1	Flat Washer Φ17*Φ30*3	24
(7)	1	Cable Φ5.5*Φ1.6*330	6	(18)	1	Spring Washer Φ16	12
(8)	1	Pull Ring Φ6*182	12	(19)	1	Nut M16	12
(9)	1	Small Pin Φ6*45	6	(20)	1	Hex Bolt M16*110	8
(10)	1	Retaining Bracket	2	(21)	1	Hex Bolt M16*135	4
(11)	1	Long Retaining Bracket	2	(22)	1	Countersunk head screw M6*10	28

ASSEMBLY INSTRUCTIONS

Step 1

1. Install the Rear Connecting Frame (1) and Rear Short Connecting Frame (2) on the Upright Frame (23), using Flat Washer $\Phi 17*\Phi 30*3$ (17), Spring Washer $\Phi 16$ (18), M16 Nut (19) and Hex Bolt M16*110(20).
2. Connect the Retaining Bracket (10) to Rear Connecting Frame (1), using Hitch Pin (6).
3. Connect the Long Retaining Bracket (11) to Rear Short Connecting Frame (2), using Hitch Pin (6).

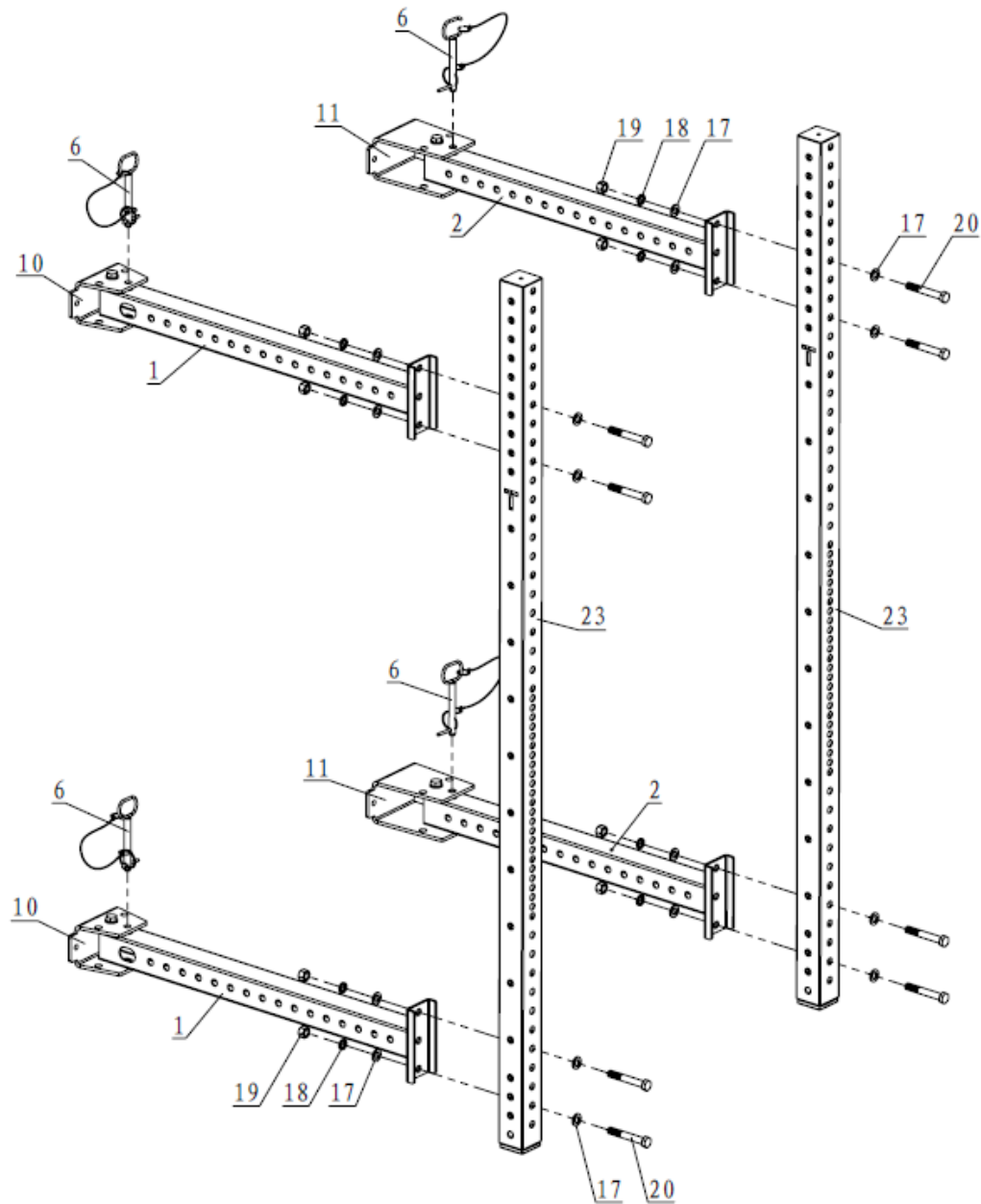

Step 2

1. Fixing the Pull Up Bar (3) on the Upright Frame (23), using the Hitch Pin (6).
2. Fixing the Retaining Bracket (10) and Long Retaining Bracket (11) on the Wall.
3. Install the Left and Right J-Hook (4&5) on the Upright Frame (23).

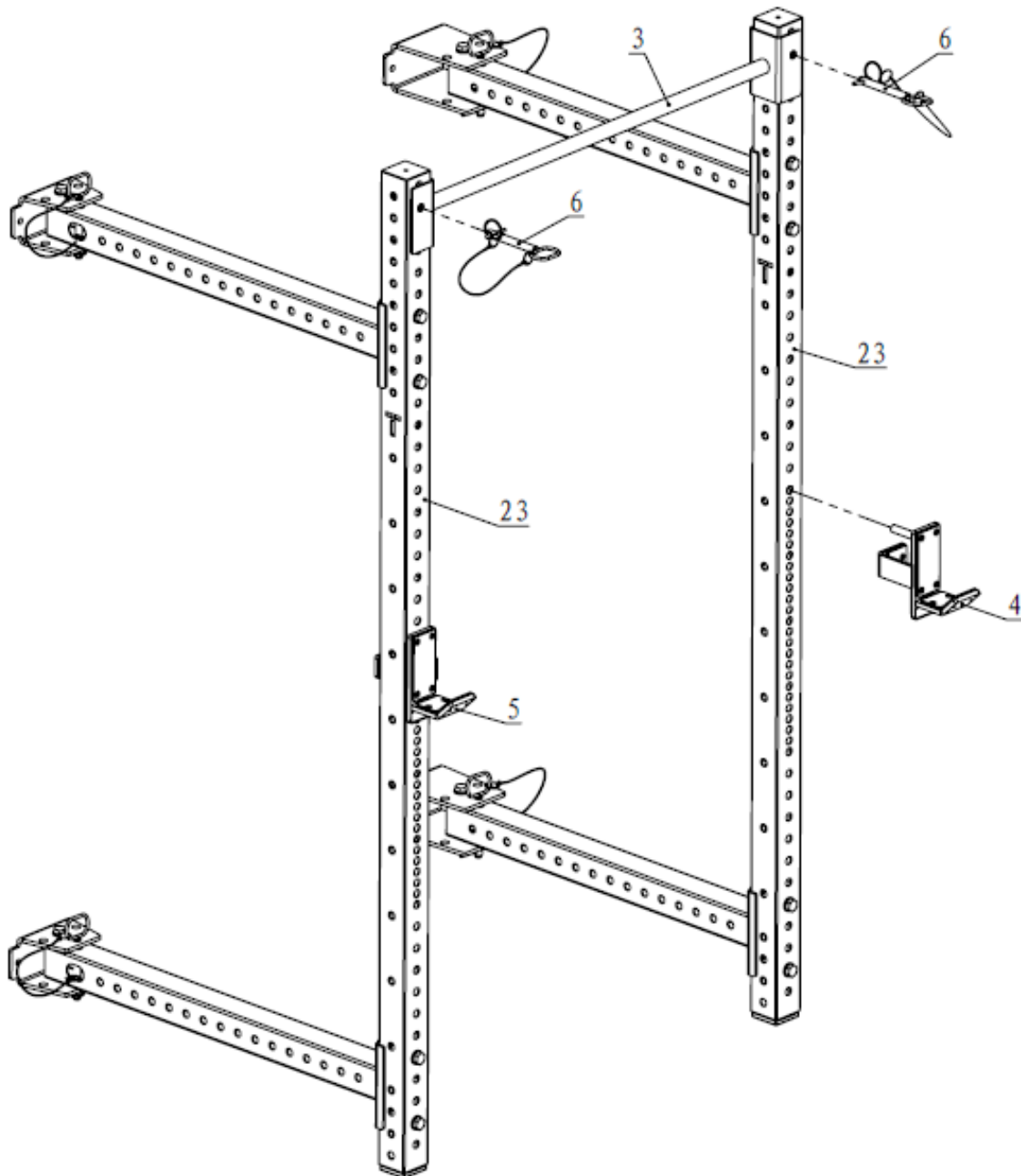

STRINGER DETAILED DIMENSIONS

Note: TITAN Fitness specifies all our products in metric(mm), and suggest measuring in metric for most accuracy. Inch dimensions provide as alternative option.

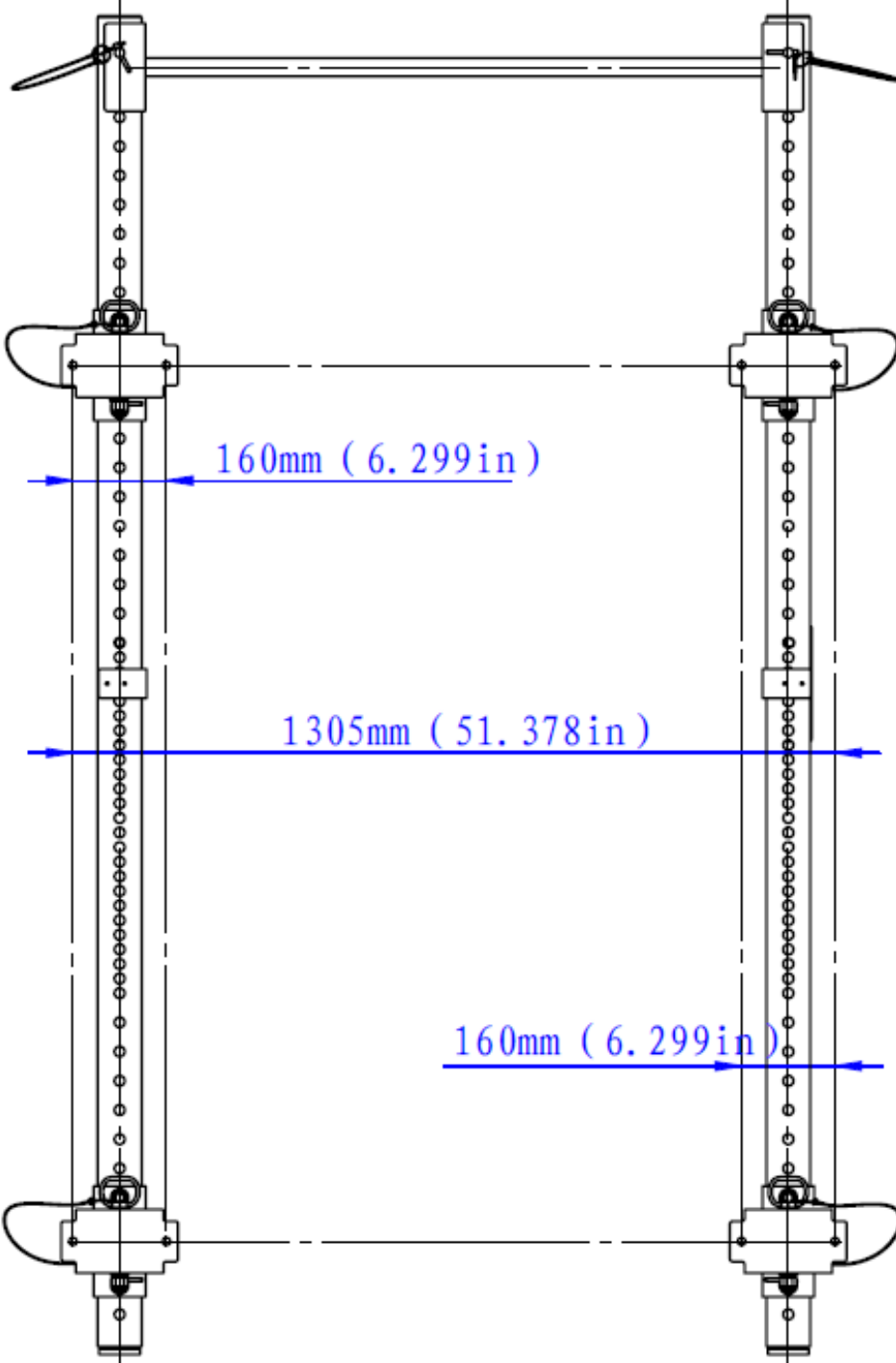

ACKNOWLEDGEMENT OF RISK AND RELEASE OF LIABILITY

The use of any equipment, including this one, involves the potential risk of injury. Apart from any warranty claim that might be presented for a claimed defect in material or workmanship of the product, you accept and assume full responsibility for any and all injuries, damages (both economic and non-economic), and losses of any type, which may occur, and you fully and forever release and discharge Titan, its insurers, employees, officers, directors, associates, and agents from any and all claims, demands, damages, rights of action, or causes of action, present or future, whether the same be known or unknown, anticipated, or unanticipated, resulting from or arising out of the use of said equipment.

This equipment must be used with care by capable and competent individuals under supervision,

WARNING



Heavy object. Use lifting aids and proper lifting techniques when moving.



Choking hazard. Small parts – Please exercise caution if small children or pets are present.



Sharp objects may be involved. Use precaution and protection.

TITAN LIMITED WARRANTY: TERMS, EXCLUSIONS AND LIMITATIONS OF REMEDIES

This product comes with a one (1) year limited warranty that can be found at www.titan.fitness/warranty.html Please review the same for all details regarding the Titan Limited Warranty.

THE TITAN LIMITED WARRANTY FOUND AT WWW.TITAN.FITNESS/WARRANTY IS EXCLUSIVE AND IS IN LIEU OF ALL OTHER WARRANTIES, EXPRESS OR IMPLIED, INCLUDING ANY IMPLIED WARRANTY OF MERCHANTABILITY AND/OR FITNESS FOR A PARTICULAR PURPOSE, EACH OF WHICH IS HEREBY DISCLAIMED.



NEED HELP? CONTACT US FIRST.

1-888-410-1503

info@titan.fitness

www.titan.fitness

© 2023 Titan Brands