

# X-3 SERIES FLAT FOOT POWER RACK

---

(2)X3FFUP82 - X3FFSB30 - X3FFACC, (2)X3FFUP92 - X3FFSB30 - X3FFACC, (2)X3FFUP82 - X3FFSB30 - X3FFACC – FWHOLD, (2)X3FFUP92 - X3FFSB30 - X3FFACC - FWHOLD  
401391, 401392, 401416, 401417



## Operator's Manual



Read the Operator's Manual entirely. When you see this symbol, the subsequent instructions and warnings are serious follow without exception. Your life and the lives of others depend on it!

**PARTS DIAGRAM / EXPLODED VIEW**

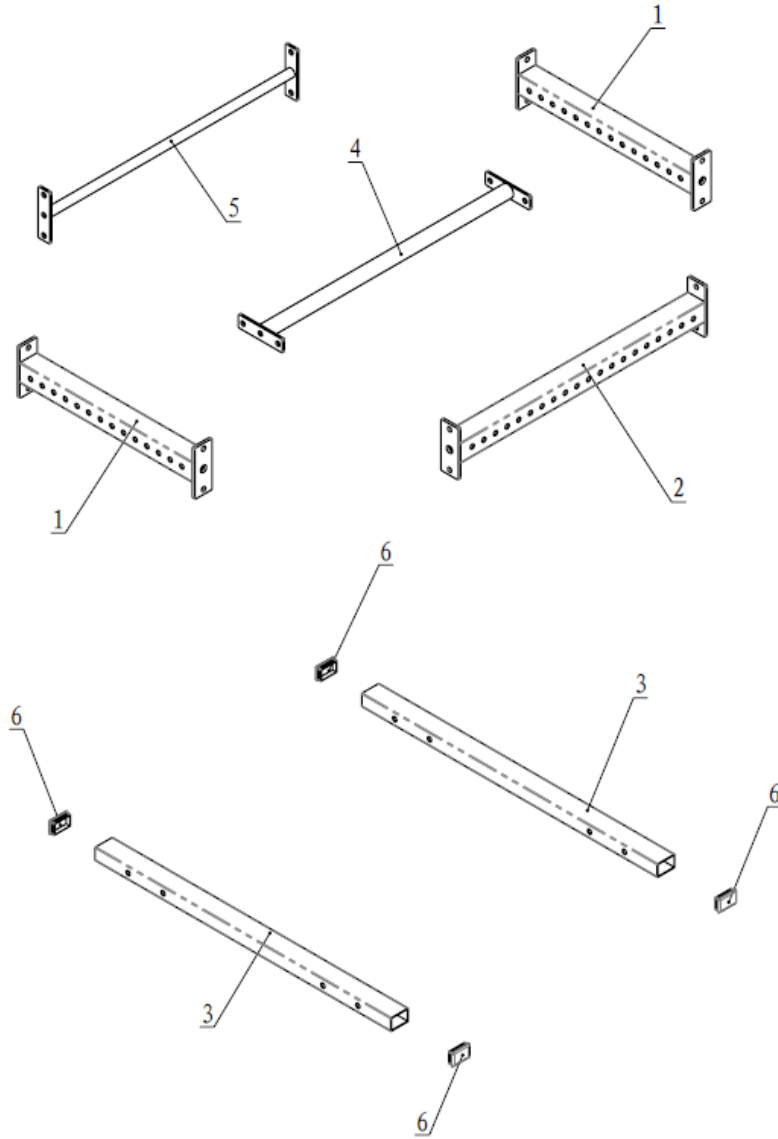

KEY	BOX	DESCRIPTION	QTY	KEY	BOX	DESCRIPTION	QTY
(1)	1	Top Connecting Frame	2	(4)	1	Rear Pull Up Bar	1
(2)	1	Rear Connecting Frame	1	(5)	1	Pull Up Bar	1
(3)	1	Base Frame	2	(6)	1	End Cap 50*75*3	4

**FWHOLD PARTS DIAGRAM / EXPLODED VIEW**

---

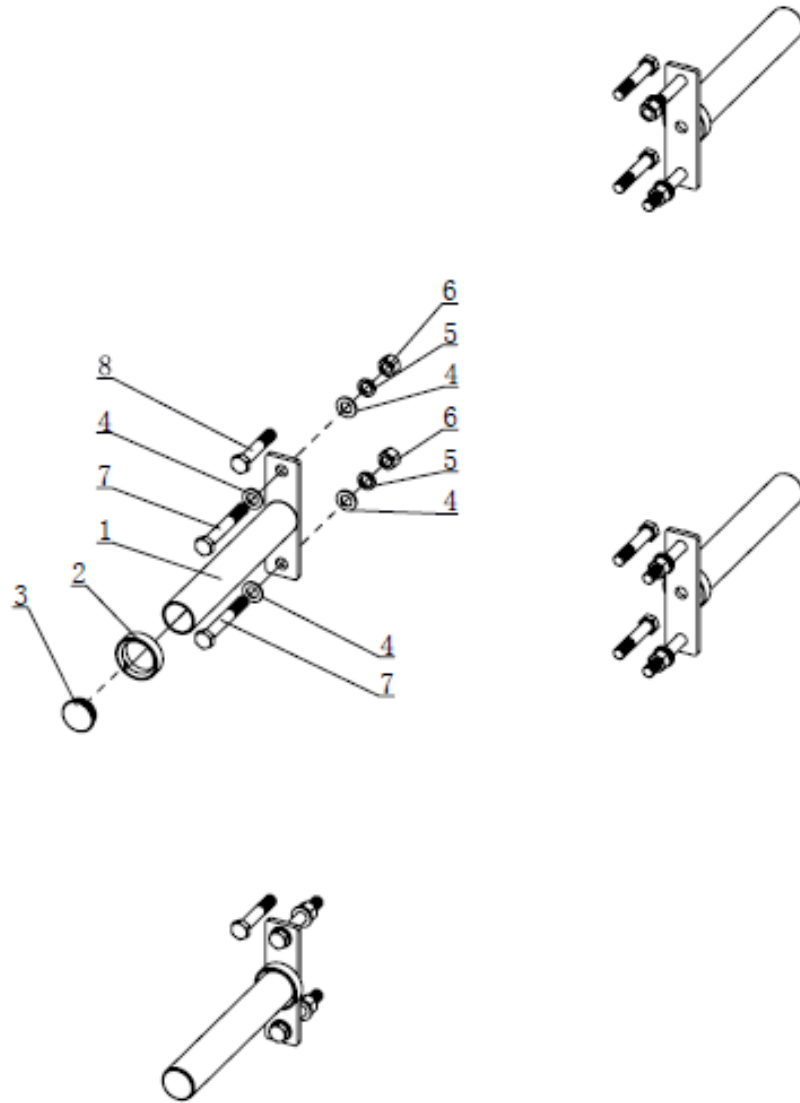

KEY	BOX	DESCRIPTION	QTY	KEY	BOX	DESCRIPTION	QTY
(1)	1	Weight Plate Holder	4	(5)	1	Spring Washer $\Phi 16$	8
(2)	1	Rubber Bumper	4	(6)	1	M16 Nut	8
(3)	1	End Cap $\Phi 48 \times 2$	4	(7)	1	Hex Bolt M16*110	8
(4)	1	Flat Washer $\Phi 17 \times \Phi 30 \times 3$	16	(8)	1	Hex Bolt M16*85	8

## 82" or 91" ASSEMBLY INSTRUCTIONS

---

### STEP 1

Assemble the Base Frame (9) and Upright Frame (16), using Fixing Plate (11), Flat Washer  $\Phi 17*\Phi 30*3$  (17), Spring Washer  $\Phi 16$  (18), Nut M16 (19) and Hex Bolt M16\*120 (21).

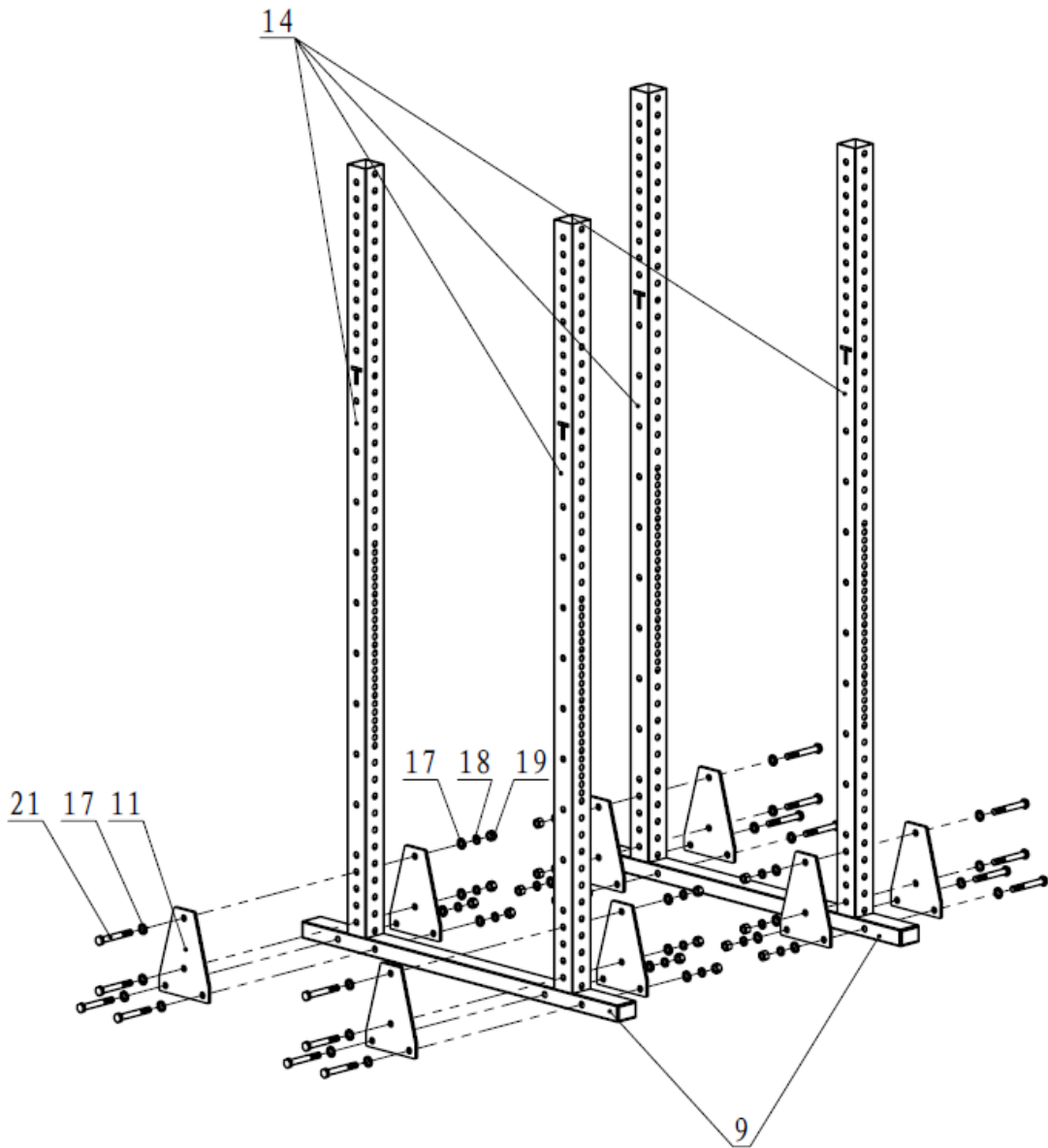

**STEP 2**

1. Assemble the Top Connecting Frame (1) and Upright Frame (16), using Flat Washer  $\Phi 17*\Phi 30*3$  (17), Spring Washer  $\Phi 16$  (18), Nut M16 (19) and Hex Bolt M16\*110 (20).
2. Connect the Pull Up Bar (5), Rear Pull Up Bar (4) Rear Connecting Frame (2) and Upright Frame (14), using Flat Washer  $\Phi 17*\Phi 30*3$  (17), Spring Washer  $\Phi 16$  (18), Nut M16 (19) and Hex Bolt M16\*110 (20).

**PLEASE TIGHTEN ALL THE BOLTS.**

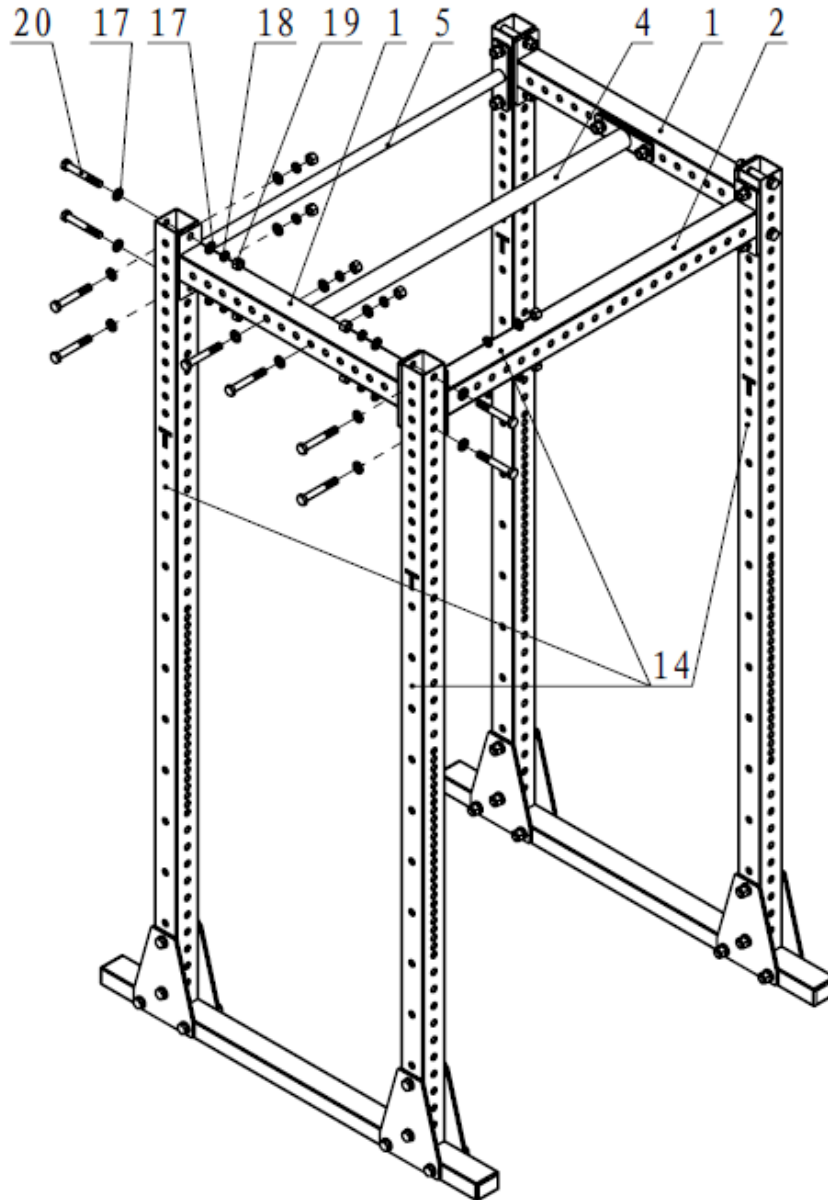

**STEP 3**

Install the Left & Right J-HOOK (9 & 10) on Upright Frame (14).

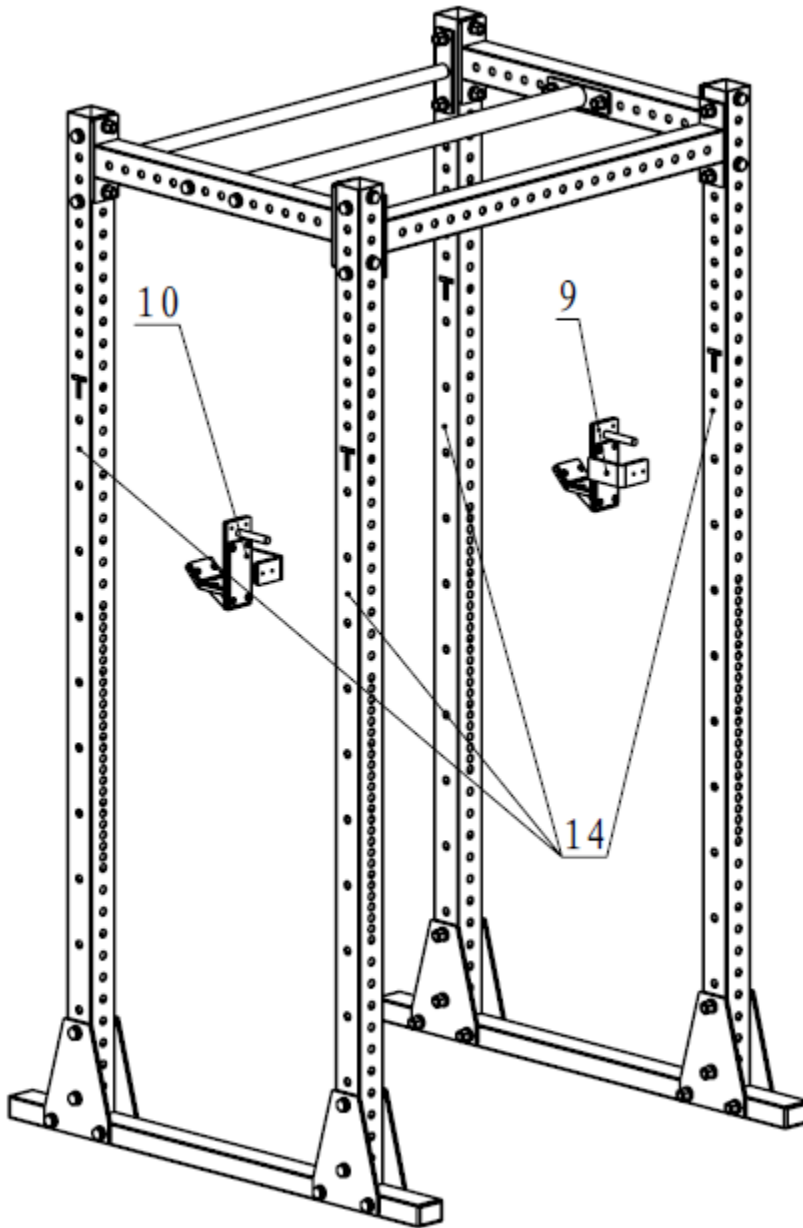

#### Step 4

Install the Weight Plate Holder (1) on the Upright Frame, using Flat Washer  $\Phi 17 \times \Phi 30 \times 3$  (4), Spring Washer (5) Nut M16 (6), and Hex Bolt M16\*110 (7).

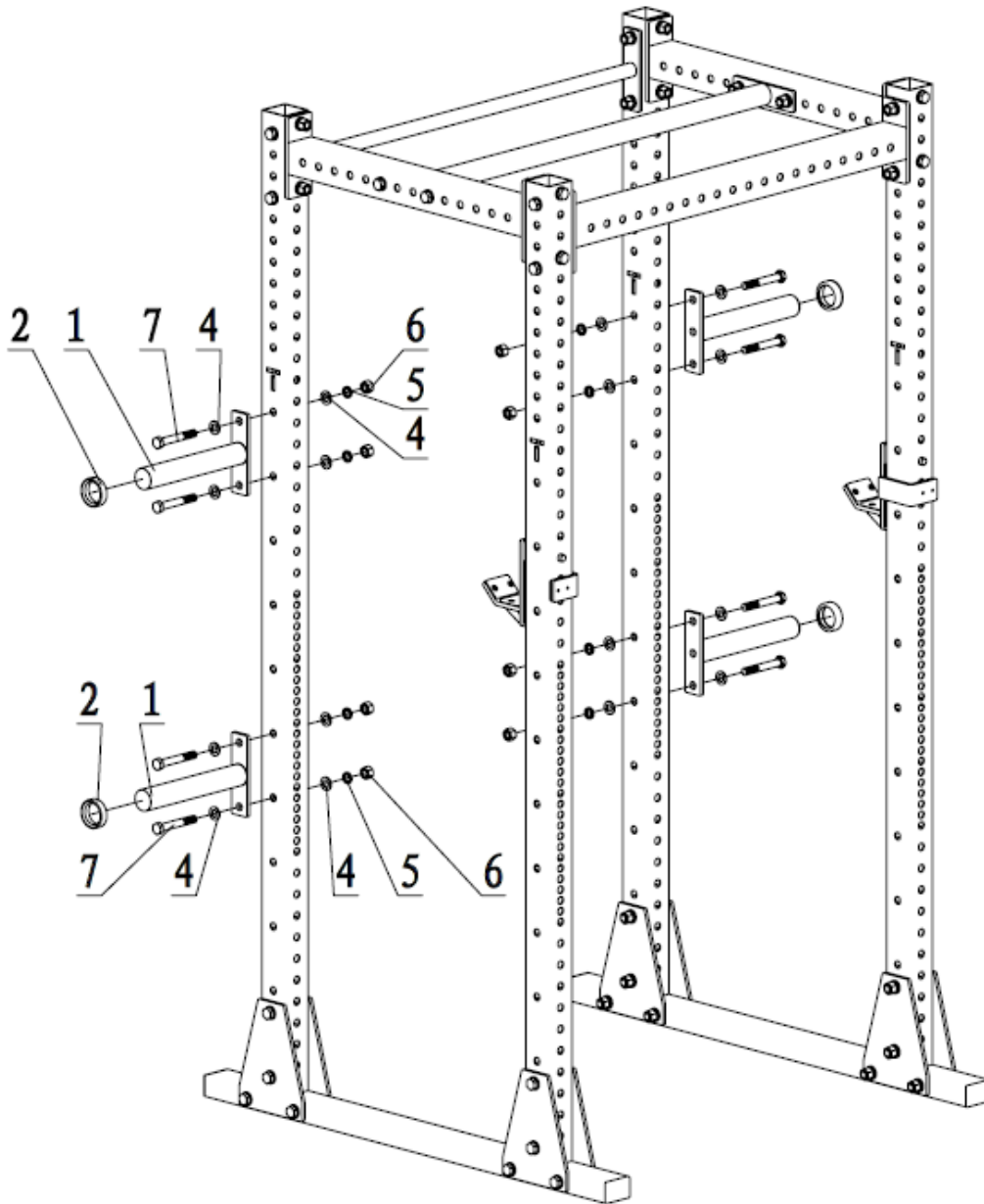

## ACKNOWLEDGEMENT OF RISK AND RELEASE OF LIABILITY

---

The use of any equipment, including this one, involves the potential risk of injury. Apart from any warranty claim that might be presented for a claimed defect in material or workmanship of the product, you accept and assume full responsibility for any and all injuries, damages (both economic and non-economic), and losses of any type, which may occur, and you fully and forever release and discharge Titan, its insurers, employees, officers, directors, associates, and agents from any and all claims, demands, damages, rights of action, or causes of action, present or future, whether the same be known or unknown, anticipated, or unanticipated, resulting from or arising out of the use of said equipment.

This equipment must be used with care by capable and competent individuals under supervision,

## WARNING

---



Heavy object. Use lifting aids and proper lifting techniques when moving.



Choking hazard. Small parts – Please exercise caution if small children or pets are present.



Sharp objects may be involved. Use precaution and protection.

## TITAN LIMITED WARRANTY: TERMS, EXCLUSIONS AND LIMITATIONS OF REMEDIES

---

This product comes with a one (1) year limited warranty that can be found at [www.titan.fitness/warranty.html](http://www.titan.fitness/warranty.html) Please review the same for all details regarding the Titan Limited Warranty.

**THE TITAN LIMITED WARRANTY FOUND AT [WWW.TITAN.FITNESS/WARRANTY](http://WWW.TITAN.FITNESS/WARRANTY) IS EXCLUSIVE AND IS IN LIEU OF ALL OTHER WARRANTIES, EXPRESS OR IMPLIED, INCLUDING ANY IMPLIED WARRANTY OF MERCHANTABILITY AND/OR FITNESS FOR A PARTICULAR PURPOSE, EACH OF WHICH IS HEREBY DISCLAIMED.**





**NEED HELP? CONTACT US FIRST.**

**1-888-410-1503**

[info@titan.fitness](mailto:info@titan.fitness)

[www.titan.fitness](http://www.titan.fitness)

© 2024 Titan Brands