

T-2 SERIES LAT TOWER

401378 - T2LATTWR_71-T2LATTWR_BASE,

401379 - T2LATTWR_83-T2LATTWR_BASE



Operator's Manual



Read the Operator's Manual entirely. When you see this symbol, the subsequent instructions and warnings are serious follow without exception. Your life and the lives of others depend on it!

PARTS DIAGRAM / EXPLODED VIEW

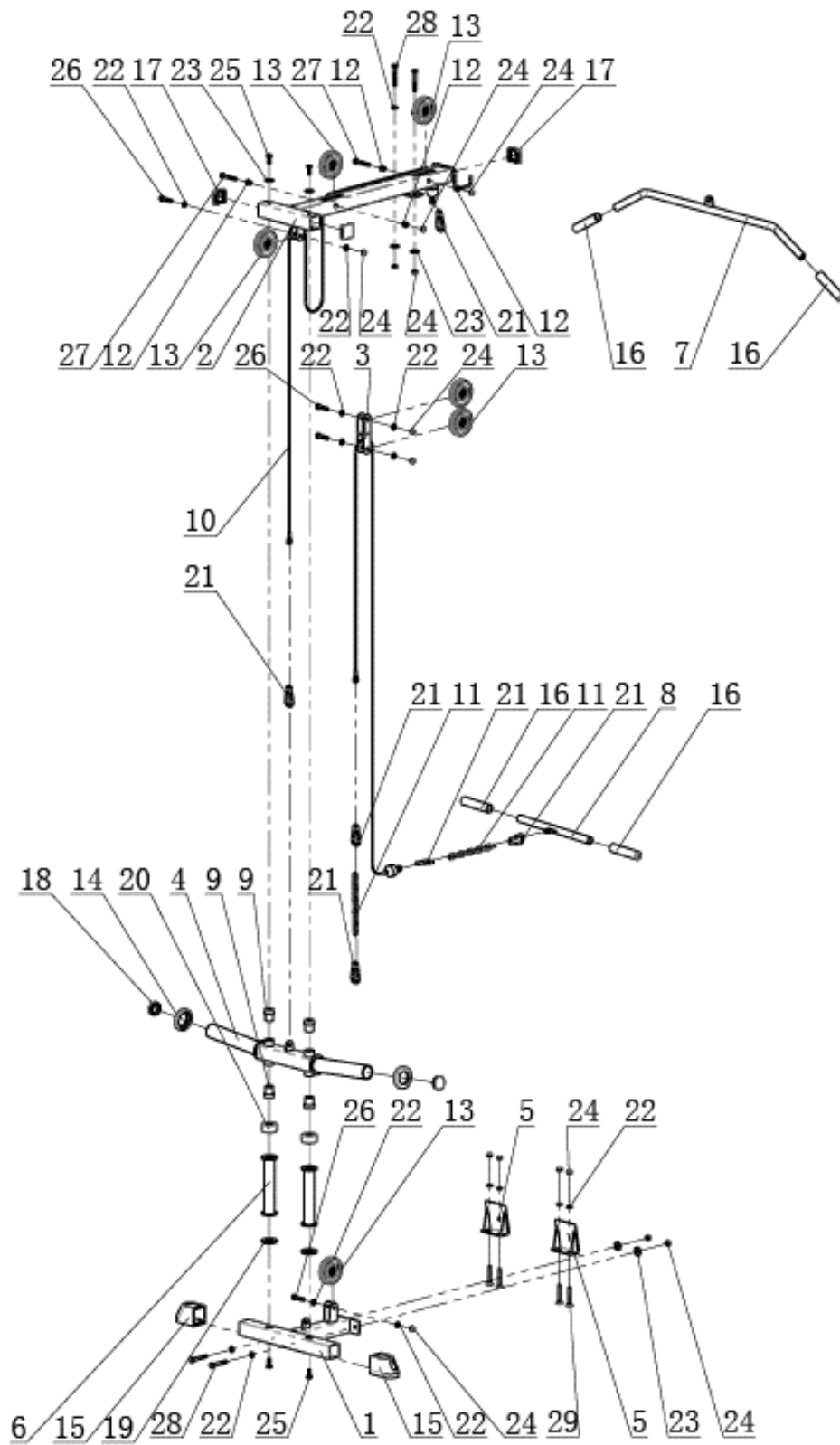

KEY	BOX	DESCRIPTION	QTY	KEY	BOX	DESCRIPTION	QTY
(1)	1	Lower Fixing Frame	1	(16)	1	Front Handlebar Grip	4
(2)	1	Upper Fixing Frame	1	(17)	1	End Cap F50*2	3
(3)	1	Movable Pulley Frame	1	(18)	1	End Cap Φ 48*2	2
(4)	1	Weight Plate Holder	1	(19)	1	Rubber Bumper Φ 55* Φ 26*5	2
(5)	1	Pedal Frame	2	(20)	1	Rubber Bumper Φ 55* Φ 25*25	2
(6)	2	Heighten Frame	2	(21)	1	HOOK Φ 8*80	6
(7)	1	Handle Bar	1	(22)	1	Flat Washer Φ 11* Φ 20*2	16
(8)	1	Lower Handle	1	(23)	1	Flat Washer Φ 10.5* Φ 30*2.5	6
(9)	1	Bushing Φ 35.5* Φ 26*39	4	(24)	1	Nut M10	14
(10)	1	Cable Φ 5*2650	2	(25)	1	Hex Bolt M10*25	4
(11)	1	Link Φ 5*230	2	(26)	1	Hex Bolt M10*45	4
(12)	1	Spacer Bush Φ 18*15	4	(27)	1	Hex Bolt M10*65	2
(13)	1	Φ 95 Pulley	6	(28)	1	Hex Bolt M10*70	4
(14)	1	Rubber Bumper Φ 77* Φ 47.5*13	2	(29)	1	Carriage Bolt M10*65	4
(15)	1	Rubber Foot	2	(30)	1	Pulley Bushing Φ 18*15	4

ASSEMBLY INSTRUCTIONS

Step 1

Insert the Guide Rod into the Weight Plate Holder (4), Rubber Bumper $\Phi 55*\Phi 25*25$ (20) and Heighten Frame (6) one by one as shown in drawing, then assemble Lower Fixing Frame (1), Upper Fixing Frame (2) and Guide Rod, using Flat Washer $\Phi 10.5*\Phi 30*2.5$ (23), and Hex Bolt M10*25 (25).

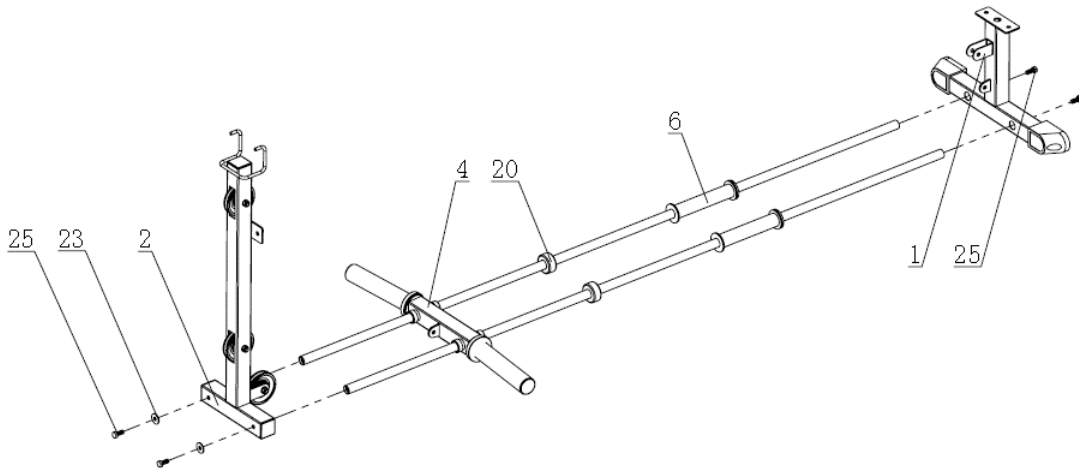

Step 2

Install Step 1 on Power Rack, using Flat Washer $\Phi 10.5*\Phi 30*2.5$ (23), Flat Washer $\Phi 11*\Phi 20*2$ (22), Nut M10 (24) and Hex Bolt M10*70 (28), then adjust the machine and tighten all bolts.

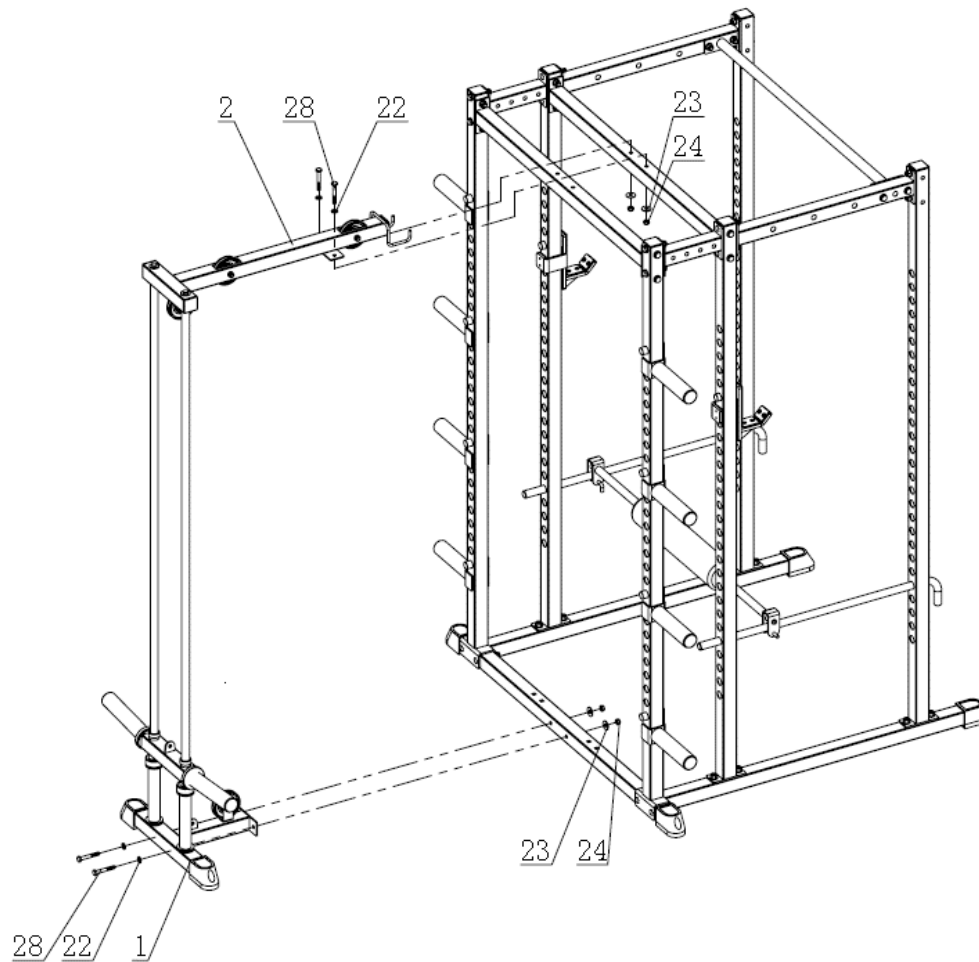

Step 3

1. Remove the Pulley (A, B, C) on the Upper Fixing Frame (2), insert the cable (10) from Pulley A, via the upper fixing frame (2) and out from the hole of Pulley B, through the pulley C Bracket, then reinstall the pulley A, B, C.
2. Remove the Pulley(F), Through one side of cable (10) into the Pulley bracket on the Base frame (1), then reinstall the pulley F.
3. Remove the Pulley(D&E) on the movable Pulley Frame (3), Place the cable (10) into the movable Pulley Frame (3), then reinstall the pulley D, E.
4. Fixing the Top cable on the Weight Plate Holder (4), using the Safety Hook (21). Fix the cable on the Base Frame (1), using Safety Hook (21) and Link (11).

Pay Attention: The Extension Cable used on the Tall T2 Lat Tower Guide Rods.

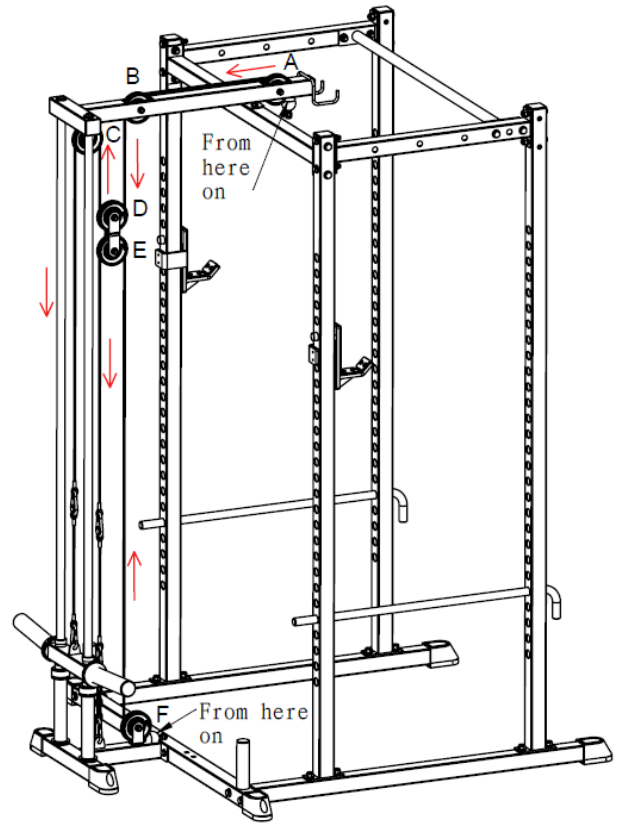
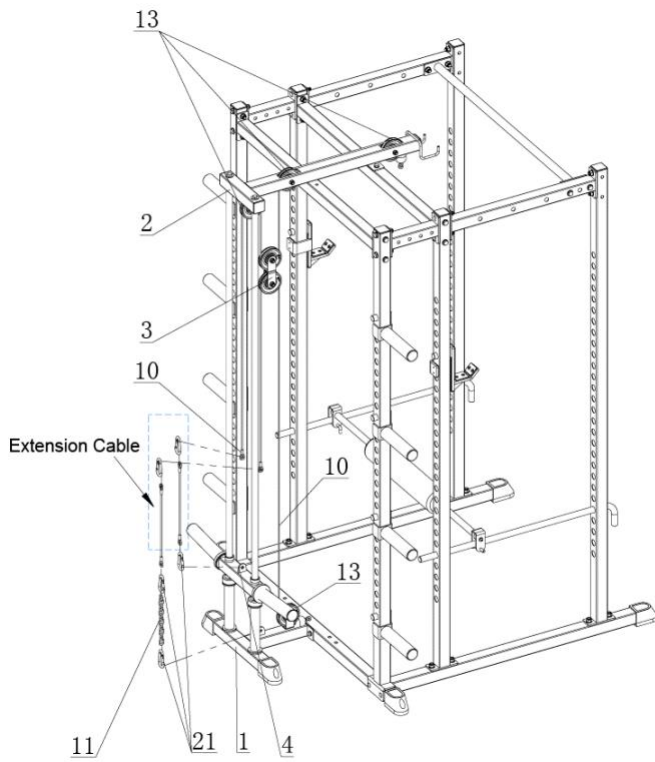

Schematic diagram of cable direction

Step 4

1. Connect the Handlebar (7) and one side of Cable (10) on the Upper Fixing Frame (2), using Hook (21). Then Hang the Handlebar on the Upper Fixing Frame (2).
2. Connect the Lower Handle (8) and one side of Cable (10) on the Lower Fixing Frame (1), using Hook (21) and Link (11).

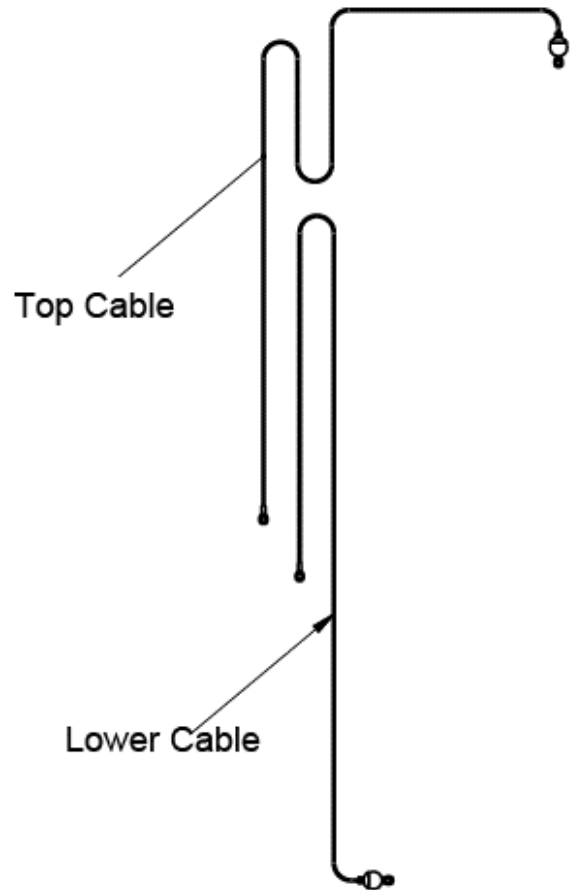

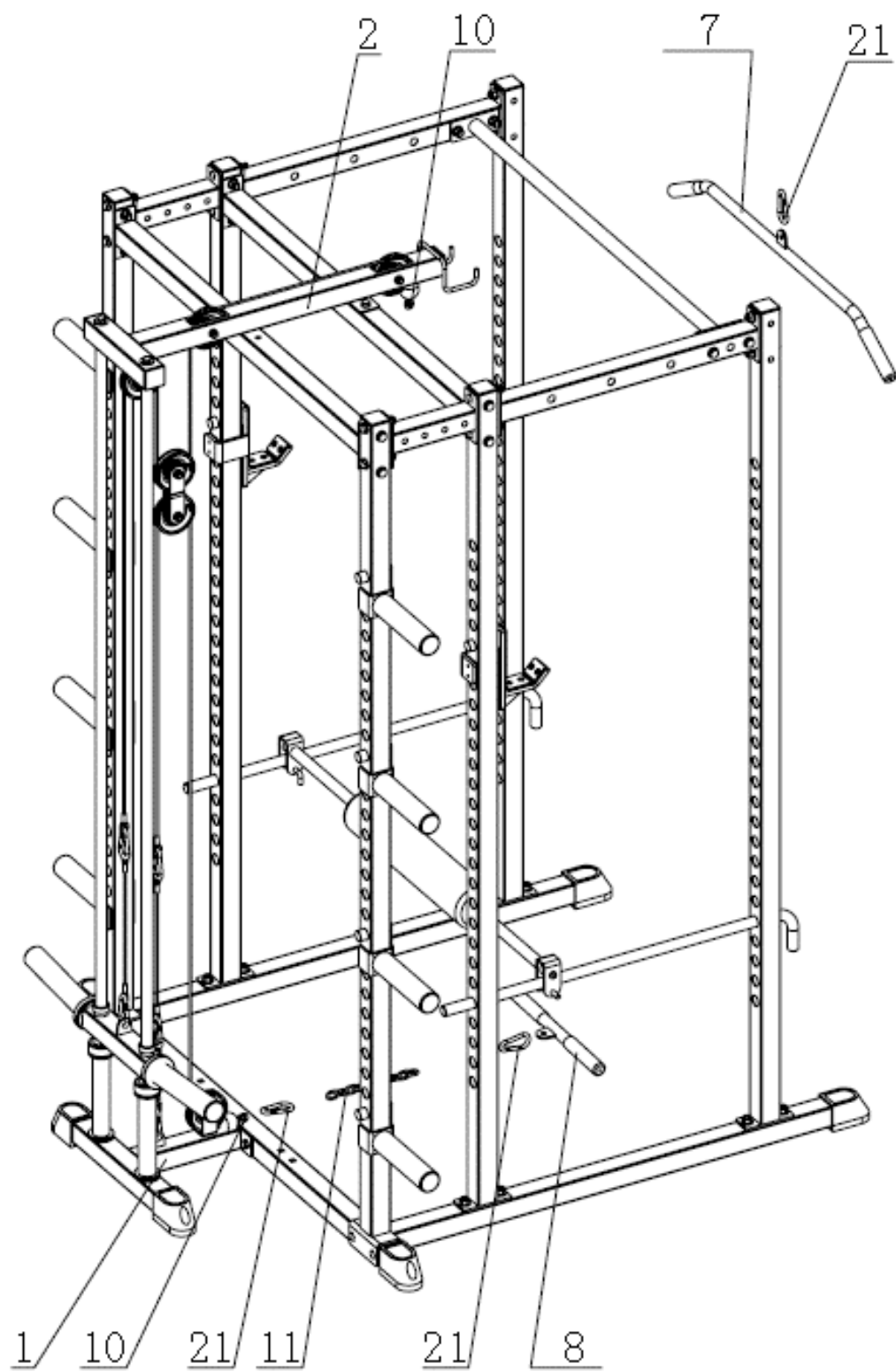

ADDITIONAL INFORMATION

Guide Rod Maintenance

Frequency: Clean monthly for regular use, more often for heavy use.

Supplies Needed:

- 2 Lint-Free Cloths
- Degreaser Spray Cleaner (e.g., Simple Green)
- Silicone Lubricant Spray (avoid oil-based lubricants like original WD-40)

Directions:

1. Use a lint-free cloth to wipe each guide rod down with a degreaser cleaner.
2. Allow to dry, then spray silicone lubricant directly on the rods before wiping completely dry with the second cloth.

ACKNOWLEDGEMENT OF RISK AND RELEASE OF LIABILITY

The use of any equipment, including this one, involves the potential risk of injury. Apart from any warranty claim that might be presented for a claimed defect in material or workmanship of the product, you accept and assume full responsibility for any and all injuries, damages (both economic and non-economic), and losses of any type, which may occur, and you fully and forever release and discharge Titan, its insurers, employees, officers, directors, associates, and agents from any and all claims, demands, damages, rights of action, or causes of action, present or future, whether the same be known or unknown, anticipated, or unanticipated, resulting from or arising out of the use of said equipment.

This equipment must be used with care by capable and competent individuals under supervision,

WARNING



Heavy object. Use lifting aids and proper lifting techniques when moving.



Choking hazard. Small parts – Please exercise caution if small children or pets are present.



Sharp objects may be involved. Use precaution and protection.

TITAN LIMITED WARRANTY: TERMS, EXCLUSIONS AND LIMITATIONS OF REMEDIES

This product comes with a one (1) year limited warranty that can be found at www.titan.fitness/warranty.html Please review the same for all details regarding the Titan Limited Warranty.

THE TITAN LIMITED WARRANTY FOUND AT WWW.TITAN.FITNESS/WARRANTY IS EXCLUSIVE AND IS IN LIEU OF ALL OTHER WARRANTIES, EXPRESS OR IMPLIED, INCLUDING ANY IMPLIED WARRANTY OF MERCHANTABILITY AND/OR FITNESS FOR A PARTICULAR PURPOSE, EACH OF WHICH IS HEREBY DISCLAIMED.



NEED HELP? CONTACT US FIRST.

1-888-410-1503

info@titan.fitness

www.titan.fitness

© 2024 Titan Brands